

Heller

LEOPARD 2A4 DEUTSCHES HEER

30800



Français

Le Leopard 2 est un char de combat de fabrication allemande produit en série depuis 1978. Au cours de cette longue période de production, de nombreuses options de modernisation et spécifications ont été développées pour les clients étrangers. Par conséquent, il existe diverses variantes du Leopard 2. Il a été utilisé dans un certain nombre de conflits, plus récemment dans la guerre russo-ukrainienne.

Le Leopard 2A4 a été fabriqué en quatre lots comprenant 695 véhicules. La production du 5e lot a commencé en décembre 1985 et s'est terminée en mars 1987. Le 8e lot a été achevé le 19 mars 1992 avec la remise solennelle du dernier Leopard 2A4 produit pour la Bundeswehr au 8e bataillon blindé de montagne.

La plupart des véhicules sont des modèles mixtes et se composent, par exemple, de caisses du premier lot de construction et de tourelles du sixième au huitième lot.

Dix Leopard 2A4 ont été démilitarisés ou affectés à des expositions.

Si l'armée allemande ne l'utilise plus, le Leopard 2A4 est toujours en service chez des partenaires tels que l'Autriche, les Pays-Bas, la Grèce et l'Espagne ainsi que sur le front ukrainien.

Le Leopard 2A4 est la version la plus répandue de la série Leopard 2 et aussi la plus importante d'un point de vue historique, car elle marque la fin des modèles classiques avec blindage vertical de la tourelle avant l'introduction du blindage en angle (à partir de la version A5).

English

The Leopard 2 is a German-made main battle tank that has been in series production since 1978. During this long production run, numerous optional upgrades and specifications for foreign customers were developed. As a result, there are a large number of Leopard 2 variants. It saw action in a number of conflicts, most recently in the Russo-Ukrainian War.

Production of the Leopard 2A4 comprised four batches totaling 695 vehicles. The fifth batch began in December 1985 and ended in March 1987. The eighth batch concluded on March 19, 1992, with a ceremonial handover of the last Leopard 2A4 produced for the German Armed Forces to Mountain Panzer Battalion 8.

A large proportion of the vehicles are mixed batches, consisting, for example, of hulls from the first batch and turrets from the sixth to eighth batches.

Ten Leopard 2A4s have been demilitarized or designated for exhibition.

While the German Armed Forces no longer use it, the Leopard 2A4 is still in service with partners such as Austria, the Netherlands, Greece and Spain, as well as in the war in Ukraine.

The Leopard 2A4 is the most widespread variant of the Leopard 2 family and the most historically significant variant, as it marks the end of the classic designs with vertical turret armor before the introduction of wedge armor (starting with the A5).

Deutsch

Der Leopard 2 ist ein Kampfpanzer aus deutscher Produktion und wird seit 1978 in Serie gebaut. In dieser langen Produktionszeit entstanden viele optionale Nachrüstmöglichkeiten und Spezifikationen für ausländische Abnehmer. Daher gibt es vom Leopard 2 eine Vielzahl von Varianten. Er kam in einer Reihe von Konflikten zum Einsatz, zuletzt im Russisch-Ukrainischen Krieg.

Die Fertigung des Leopard 2A4 erstreckte sich auf vier Baulose mit 695 Fahrzeugen. Das 5. Baulos der Fertigung begann im Dezember 1985 und endete im März 1987. Das 8. Baulos endete am 19. März 1992 mit einer feierlichen Übergabe des letzten produzierten Leopard 2A4 der Bundeswehr an das Gebirgspanzerbataillon 8.

Ein Großteil der Fahrzeuge sind Mischlose und bestehen z.B. aus Wannen des ersten Bauloses und Türmen aus dem sechsten bis achten Baulos.

Zehn Leopard 2A4 wurden demilitarisiert oder für Ausstellungen vorgesehen.

Während die Bundeswehr ihn nicht mehr nutzt, ist der Leopard 2A4 bei Partnern wie Österreich, Niederlande, Griechenland und Spanien weiterhin im Dienst, sowie im Ukraine Krieg.

Der Leopard 2A4 ist die am weitesten verbreitete Variante der Leopard 2 Familie und historisch bedeutendste Variante, denn er markiert den Endpunkt der klassischen Ausführungen mit vertikaler Turmpanzerung, bevor die Keilpanzerung (ab A5) eingeführt wurde.

Español

El Leopard 2 es un carro de combate de producción alemana y se fabrica en serie desde 1978. Durante este largo período de producción surgieron numerosas opciones de modernización y especificaciones para clientes extranjeros. Es por eso que existen muchas variantes del Leopard 2. Ha sido empleado en una serie de conflictos, más recientemente en la guerra ruso-ucraniana.

La producción del Leopard 2A4 se desarrolló en cuatro lotes de fabricación, con un total de 695 vehículos. La del quinto lote comenzó en diciembre de 1985 y finalizó en marzo de 1987. La producción del octavo lote finalizó el 19 de marzo de 1992 con la entrega solemne del último Leopard 2A4 producido para el ejército alemán al Batallón de Carros de Combate de Montaña 8.

La mayor parte de los vehículos son mixtos y están compuestos, por ejemplo, por cascos del primer lote y torres de los lotes seis a ocho.

Diez Leopard 2A4 fueron desmilitarizados o destinados a exposiciones.

Aunque el ejército alemán ya no lo utiliza, el Leopard 2A4 sigue en servicio en países socios como Austria, Países Bajos, Grecia y España, así como en la guerra de Ucrania.

El Leopard 2A4 es la variante más extendida de la familia Leopard 2 e históricamente la más significativa, ya que marca el final de las versiones clásicas con blindaje vertical en la torre, antes de que se introdujera el blindaje en cuña (a partir del A5).

Italiano

Il Leopard 2 è un carro armato da combattimento di produzione tedesca, costruito in serie dal 1978. In questo lungo periodo di produzione sono state sviluppate numerose opzioni di ammodernamento e specifiche per i clienti stranieri. Di conseguenza, esistono numerose varianti del Leopard 2. È stato utilizzato in una serie di conflitti, più recentemente nella guerra russo-ucraina.

La produzione del Leopard 2A4 si è estesa su quattro lotti di costruzione per un totale di 695 veicoli. Il quinto lotto di produzione è iniziato nel dicembre 1985 e si è concluso nel marzo 1987. L'ottavo lotto si è concluso il 19 marzo 1992 con una cerimonia di consegna dell'ultimo Leopard 2A4 prodotto dalla Bundeswehr al Gebirgspanzerbataillon 8 (8° battaglione corazzato da montagna).

La maggior parte dei veicoli sono misti e sono costituiti, ad esempio, da vasche del primo lotto di costruzione e torri dal sesto all'ottavo lotto di costruzione.

Dieci Leopard 2A4 sono stati smilitarizzati o destinati ad esposizioni.

Sebbene la Bundeswehr non lo utilizzi più, il Leopard 2A4 è ancora in servizio presso partner come l'Austria, Paesi Bassi, Grecia e Spagna, nonché nella guerra in Ucraina.

Il Leopard 2A4 è la variante più diffusa della famiglia Leopard 2 e la variante storicamente più significativa, poiché segna la fine delle versioni classiche con corazza a torre verticale prima dell'introduzione della corazza a cuneo (a partire dall'A5).

Nederlands

De Leopard 2 is een gevechtstank van Duitse makelij en wordt sinds 1978 in serie gebouwd. In deze lange productietijd zijn er veel optionele uitbreidingsmogelijkheden en specificaties voor buitenlandse klanten ontstaan. Daarom zijn er verschillende varianten van de Leopard 2. Deze tank werd gebruikt in een aantal conflicten, waarvan de meest recente de Russisch-Oekraïense oorlog.

De productie van de Leopard 2A4 omvatte vier bouwpartijen met 695 voertuigen. De vijfde bouwfase van de productie begon in december 1985 en eindigde in maart 1987. De achtste bouwfase eindigde op 19 maart 1992 met een plechtige overdracht van de laatst geproduceerde Leopard 2A4 van de Bundeswehr aan het achtste bergpanzerbataljon.

Het merendeel van de voertuigen zijn gemengde partijen en bestaan bijvoorbeeld uit carrosserieën van de eerste bouwfase en torens van de zesde tot en met de achtste bouwfase.

Tien Leopard 2A4's werden gedemilitariseerd of bestemd voor tentoonstellingen.

Hoewel de Bundeswehr de tank niet langer gebruikt, is de Leopard 2A4 nog steeds in dienst bij partners zoals Oostenrijk, Griekenland, Nederland en Spanje, evenals in de oorlog in Oekraïne.

De Leopard 2A4 is de meest voorkomende variant van de Leopard 2-familie en historisch gezien de belangrijkste variant, omdat deze het eindpunt markeert van de klassieke versies met verticale torenpantsering voordat de wigvormige pantsering (vanaf A5) werd geïntroduceerd.



11

Argent métallique
Silver Metallic
Silber metallisch



18

Orange brillant
Orange Gloss
Orange glänzend



19

Rouge vif brillant
Bright Red Gloss
Hellrot glänzend



33

Noir mat
Matt black
Matt-Schwarz



34

Blanc mat
White Matt
Weiß matt



53

Gris métallique
Gunmetal Metallic
Grau metallisch



62

Cuir mat
Leather Matt
Leder matt



77

Bleu marine mat
Navy Blue Matt
Marineblau matt



85

Noir de carbone satiné
Coal Black Satin
Kohlenschwarz seidenmatt



92

Gris fer mat
Iron Grey Matt
Eisengrau matt



102

Vert armée mat
Army Green Matt
Armeegrün matt



103

Crème mat
Cream Matt
Crème matt



113

Rouille mat
Rust Matt
Rost matt



116

Vert foncé US mat
US Dark Green Matt
US-Dunkelgrün matt

- Si aucune teinte n'est spécifiée, peindre dans les couleurs de la version choisie. Se reporter aux pages 12 - 15 pour le détail du schéma de peinture.
- When no color is specified, paint the item with colors of chosen version. Refer to pages 12 - 15 for painting pattern.
- Wenn keine Farbe angegeben ist, Teile mit den Farben der gewählten Version bemalen. Beachten Sie die Seiten 12 - 15 für die Lackierung und Markierung.
- Cuando ningún color es especificado, pintarle con los colores del tema de la versión elegida. Vea la páginas 12 - 15 para obtener detalles de pintura.



- L'explication des pictogrammes se trouve sur les côtés de la boîte inférieure.
- The explanation of the pictograms can be found on the sides of the bottom box.
- Die Erklärungen der Piktogramme stehen auf den Seiten des Unterkartons.
- La explicación de los pictogramas se puede encontrar en los laterales del recuadro inferior.

2

Numéro de phase
Step number
Schrittnummer
Número de fase

56

Référence de couleur
Colour reference no
Farbangabe
Referencia de color

37

Numéro de pièce
Part number
Teilenummer
Número de pieza

6

Numéro de decal
Decal number
Abziehbildnummer
Número de calcomanía

1

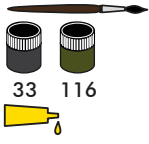

x2

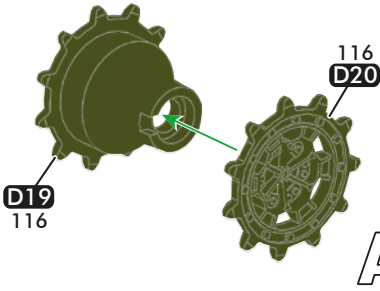

A

x14

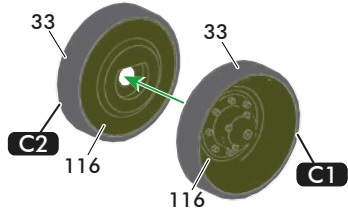

B

x2

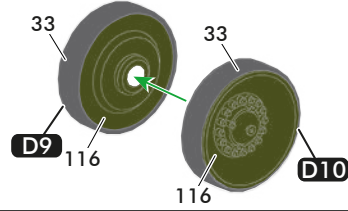

C

2

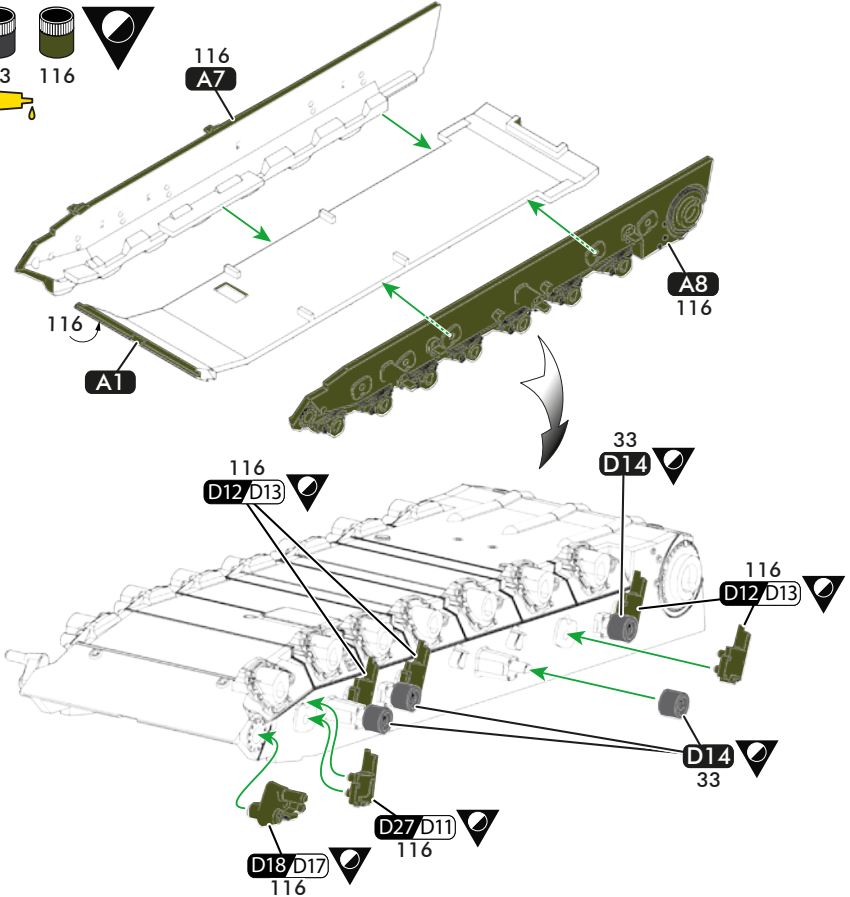

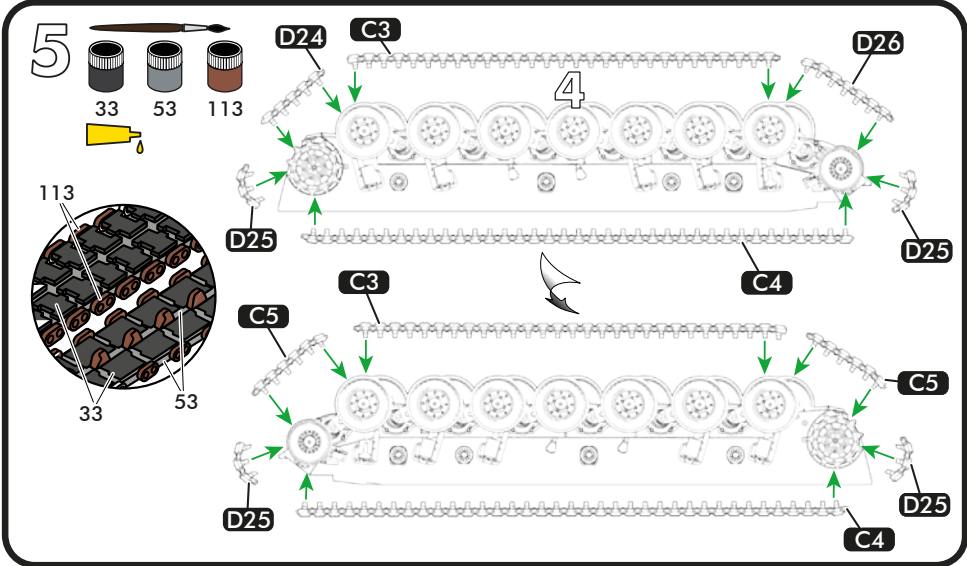
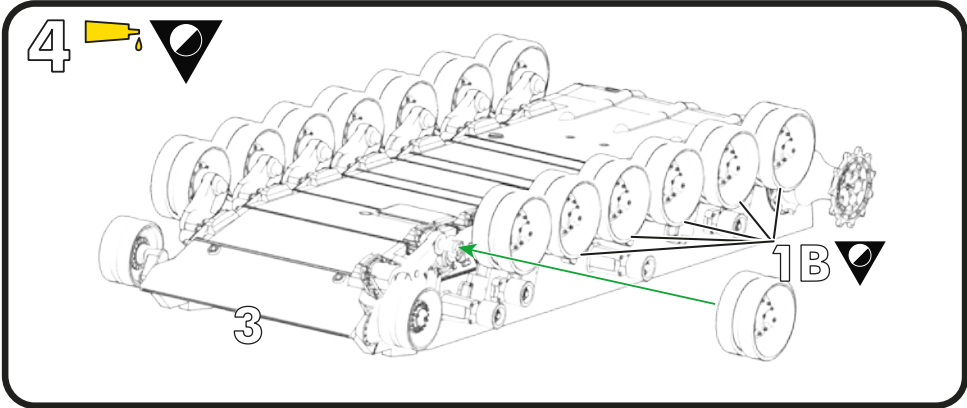
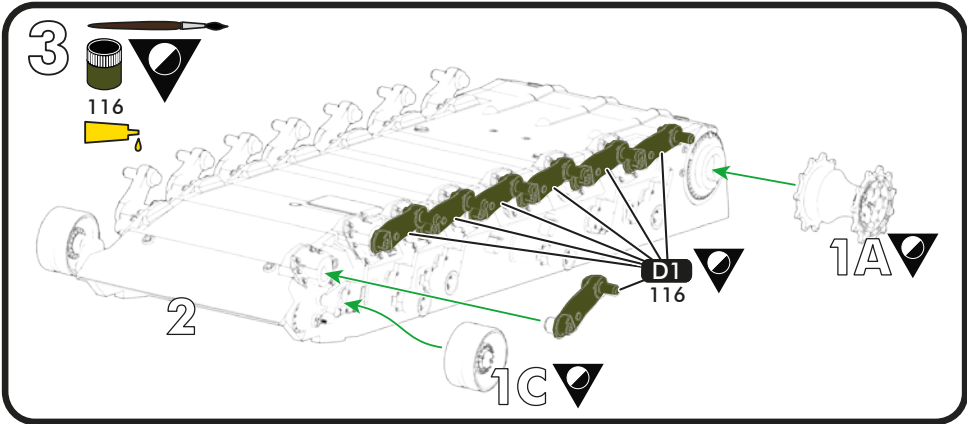

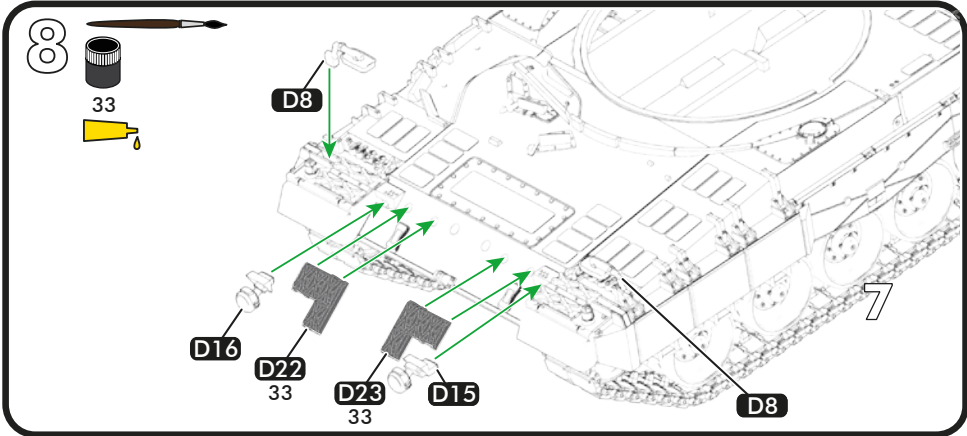
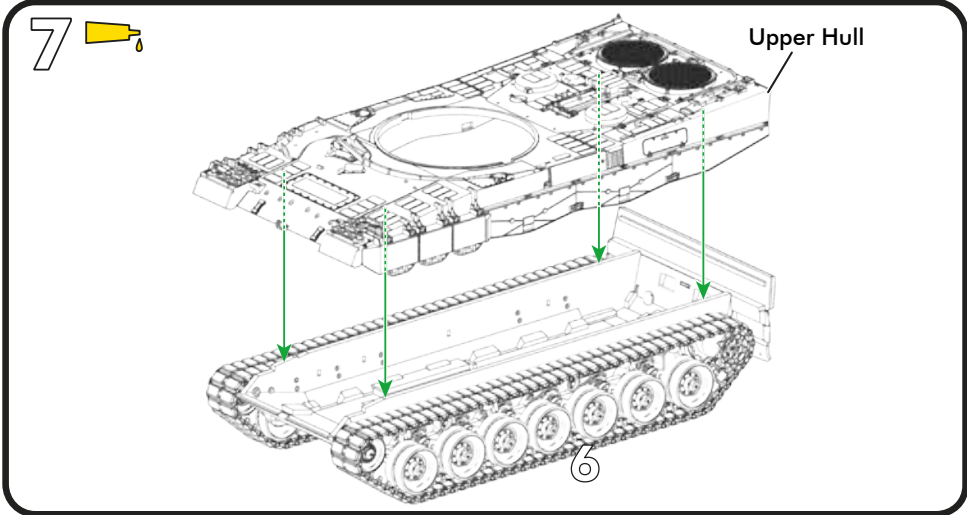
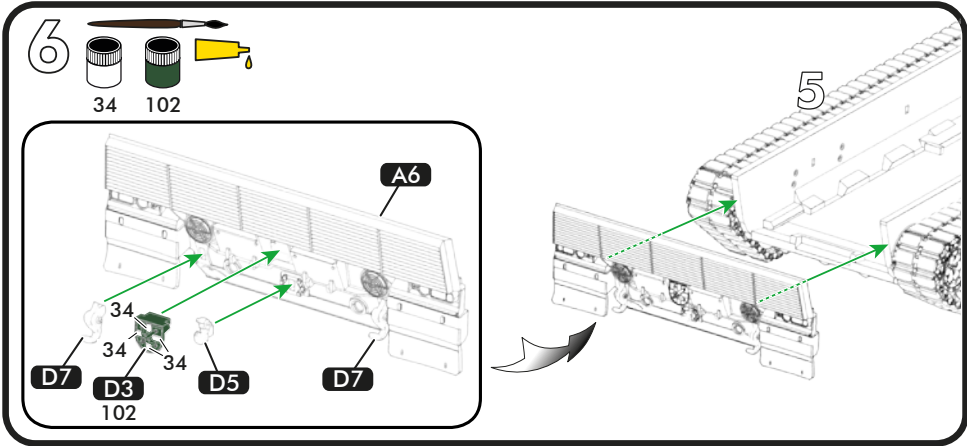

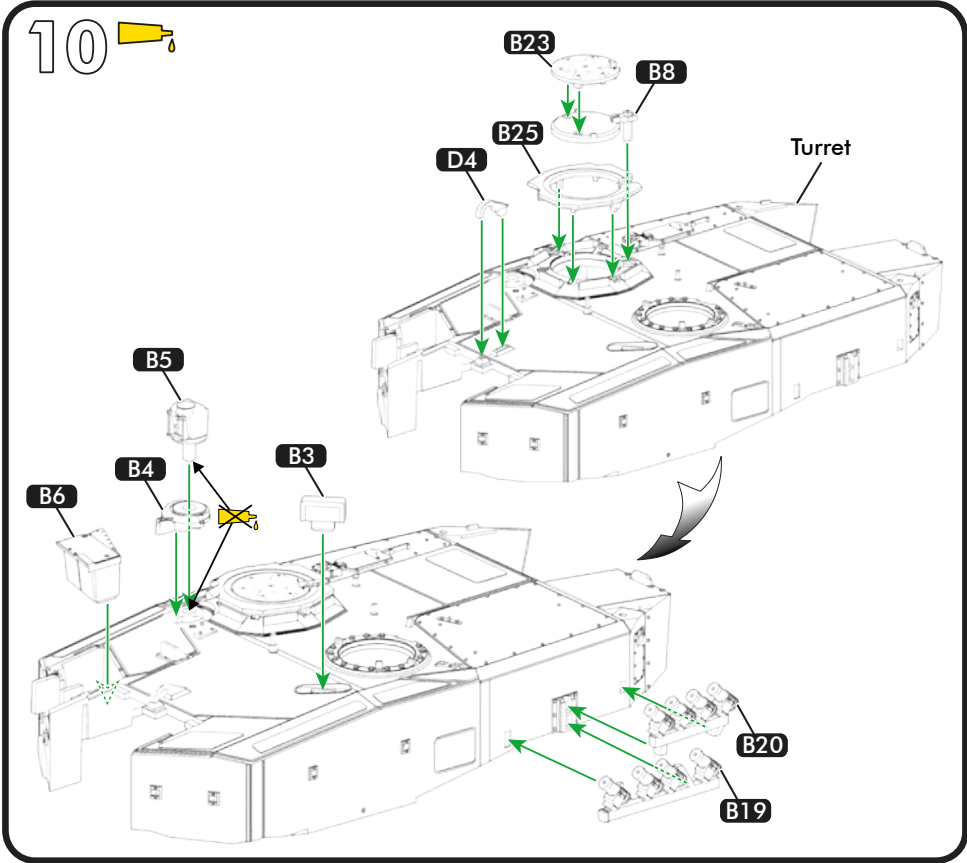
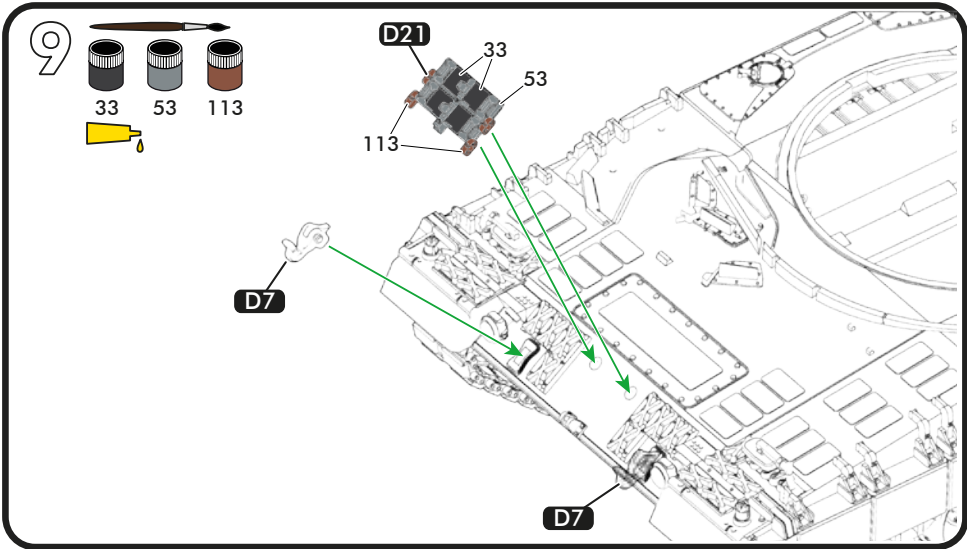

11 

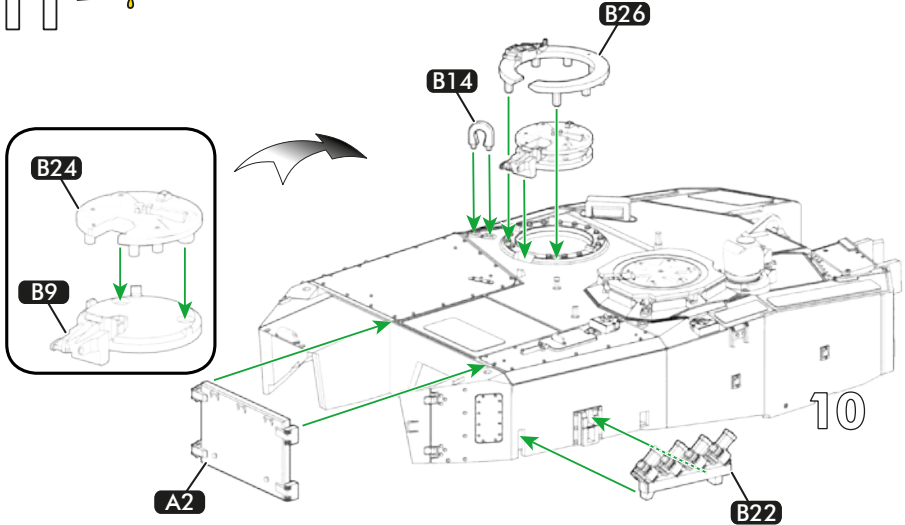

12 

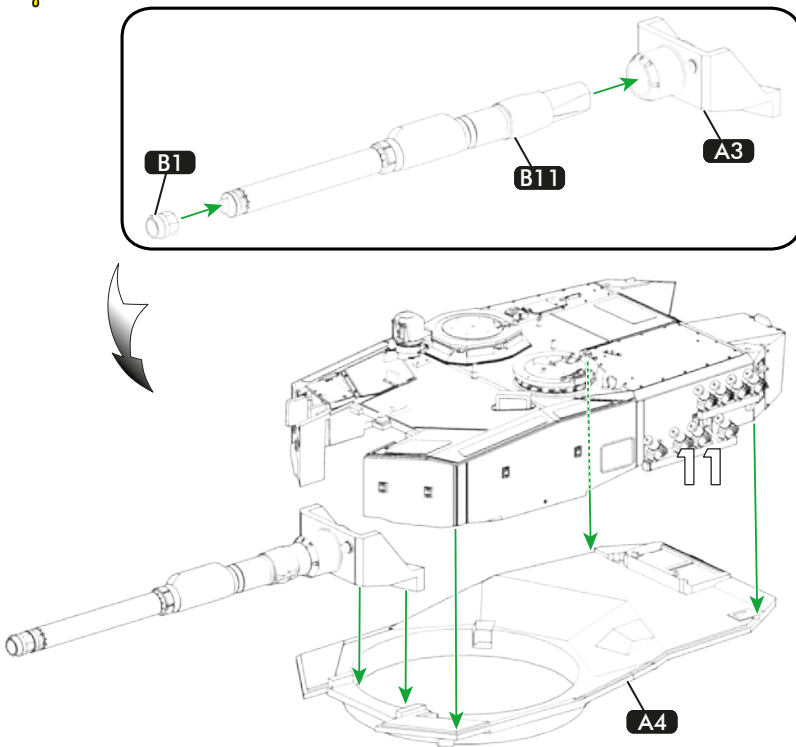

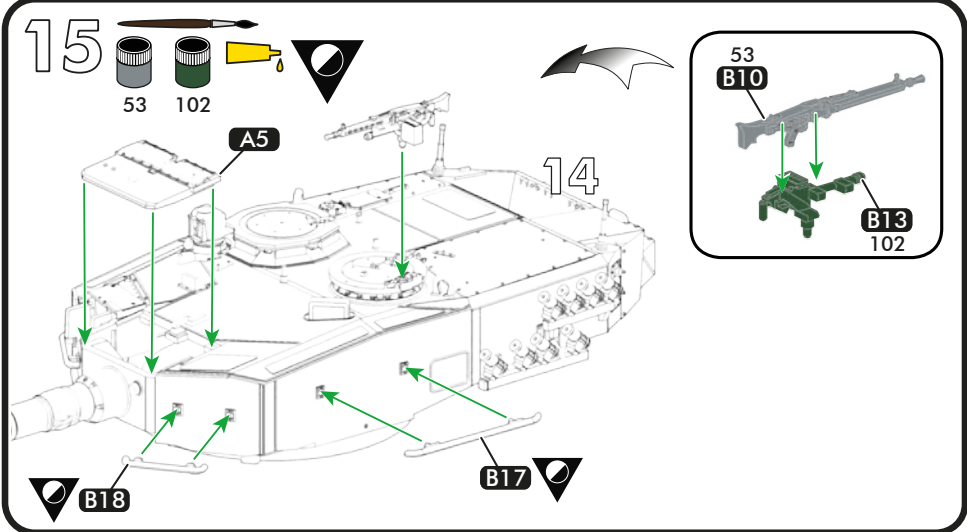
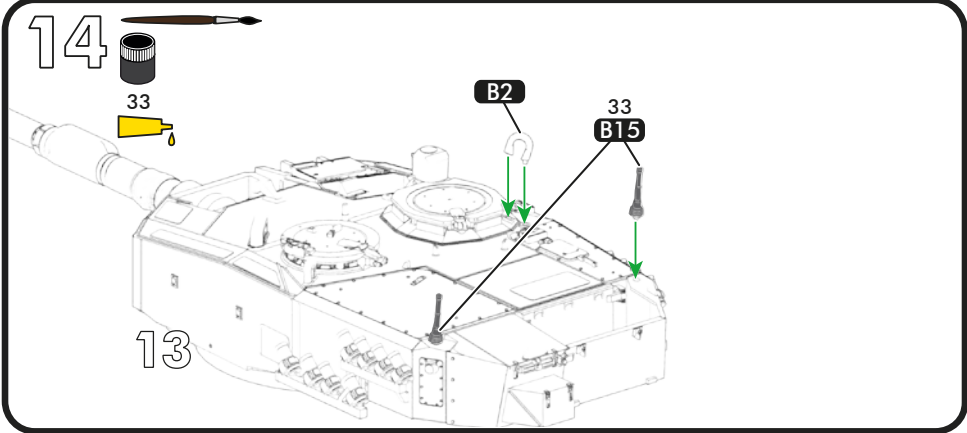
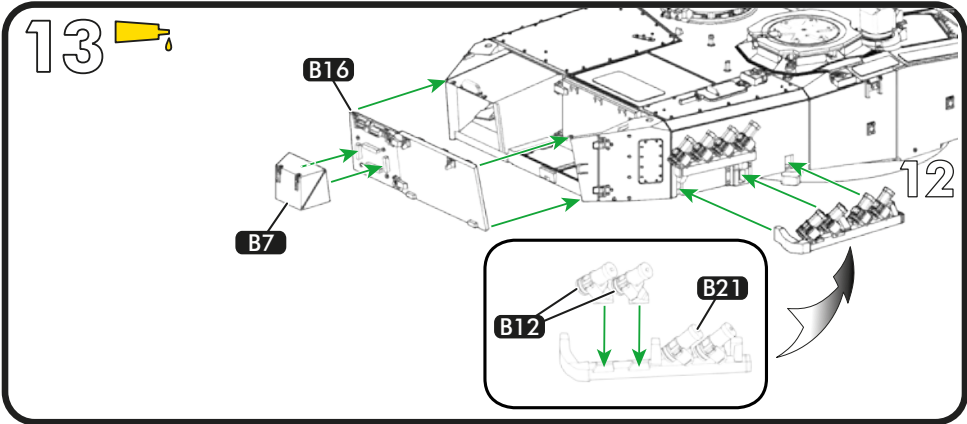

16

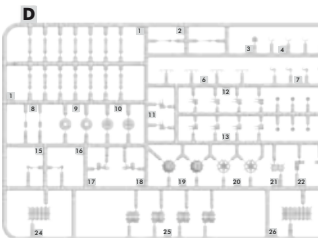
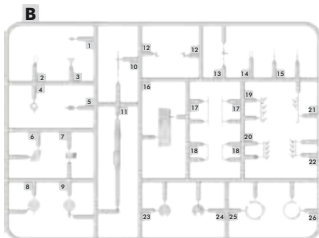
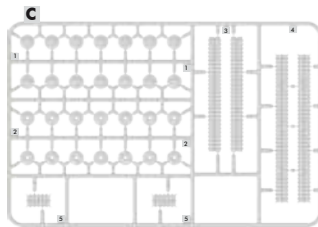
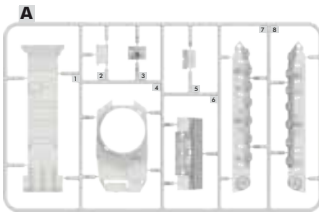
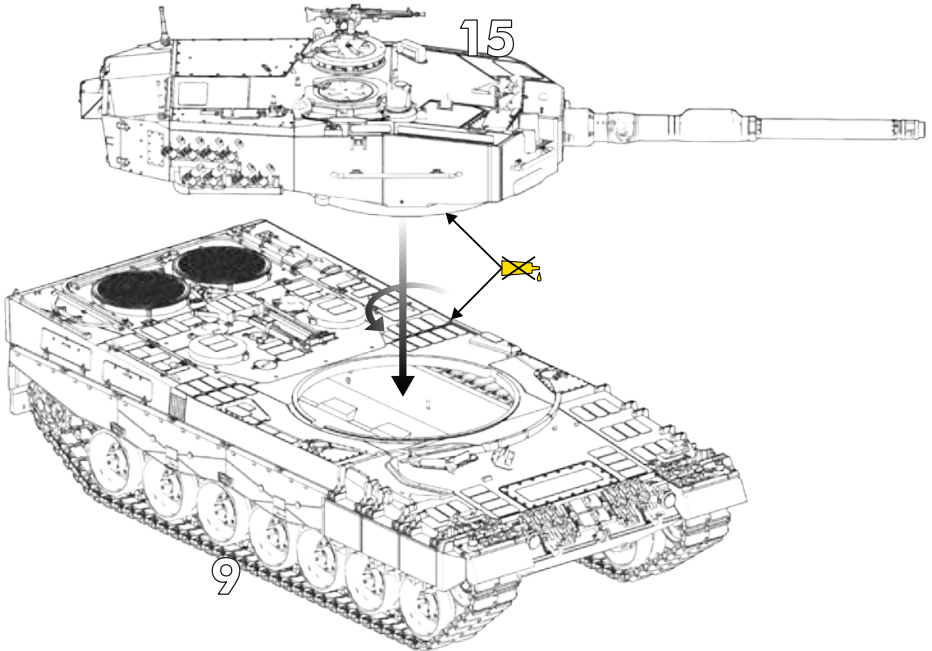

17

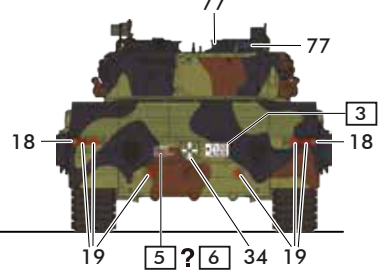
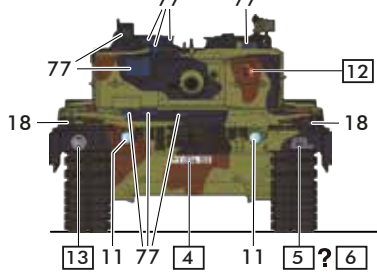
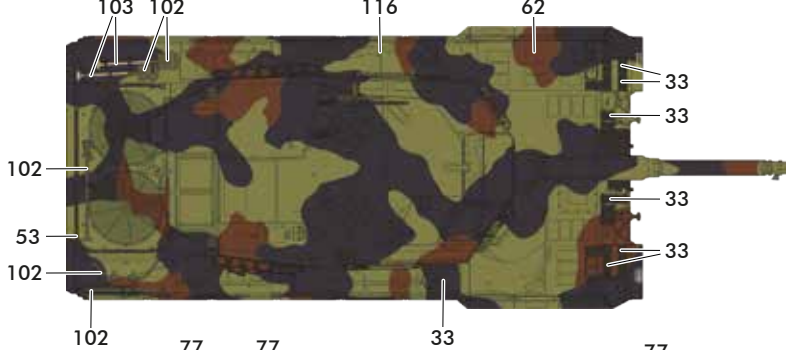
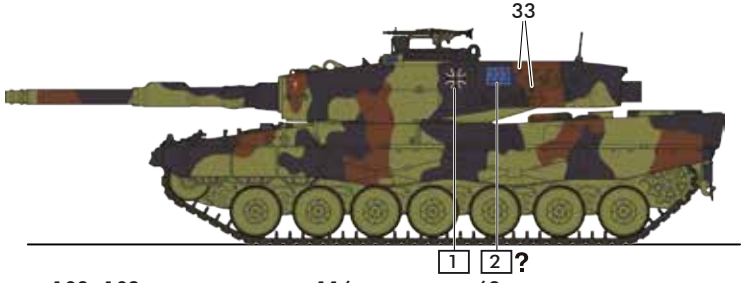
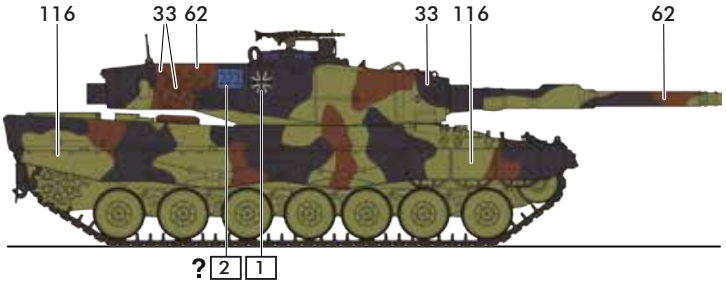
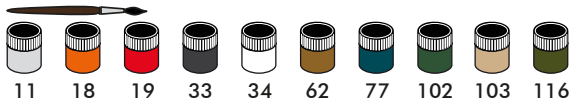

Germany: Deutsches Heer, Panzerbataillon 203, Augustdorf, 1990

17

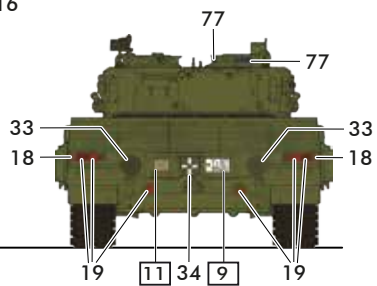
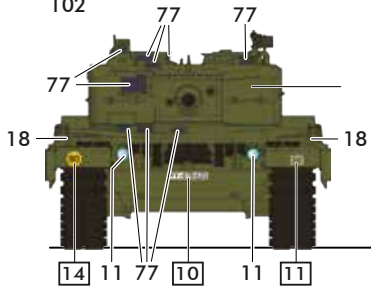
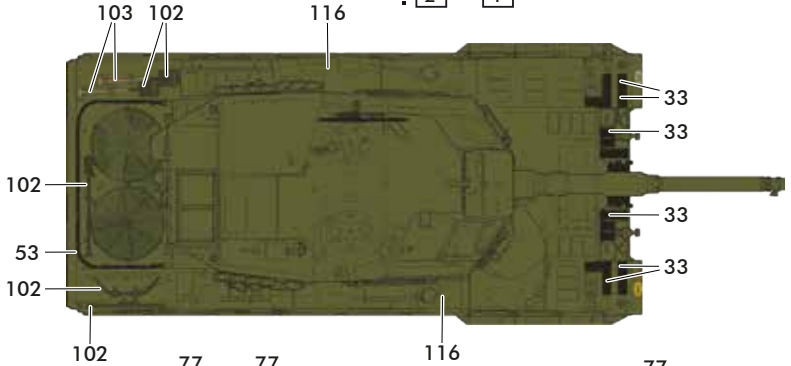
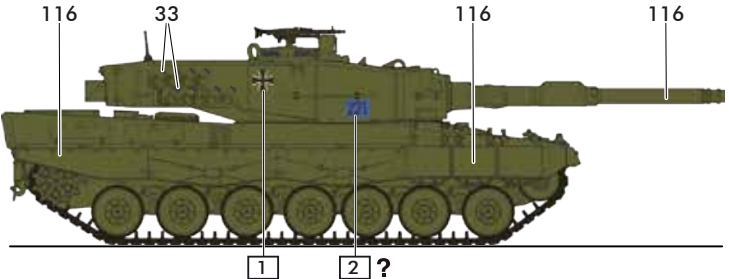
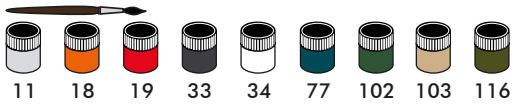

Germany: Deutsches Heer, Panzerbataillon 620, Munster, 1990

17

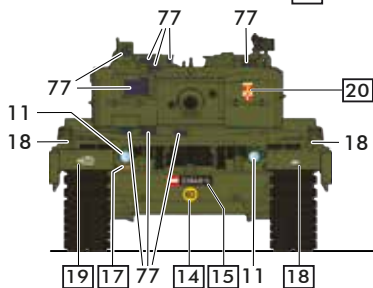
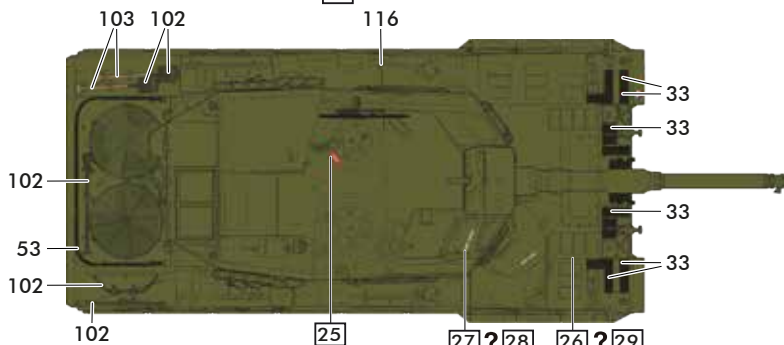
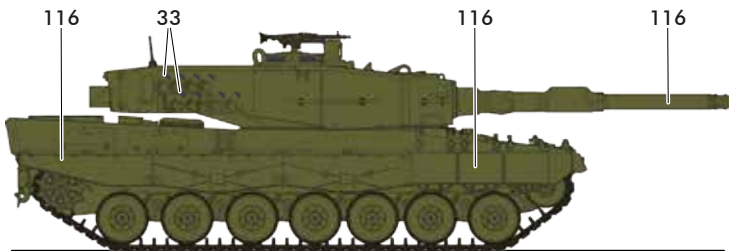
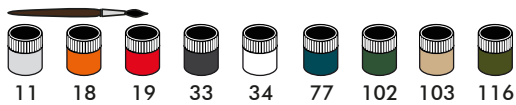

Austria: Österreichisches Bundesheer, Panzerbataillon 10 - Kommandant, 1997-2006

Thanks to IPMS Austria for the support

17

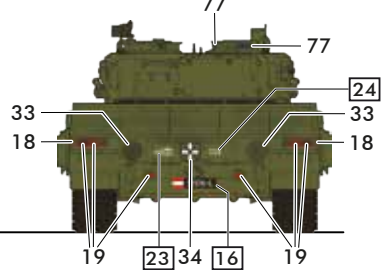
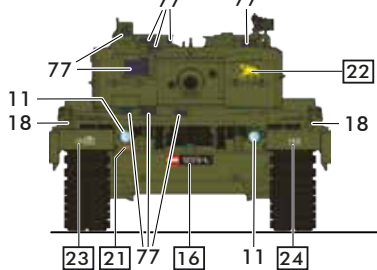
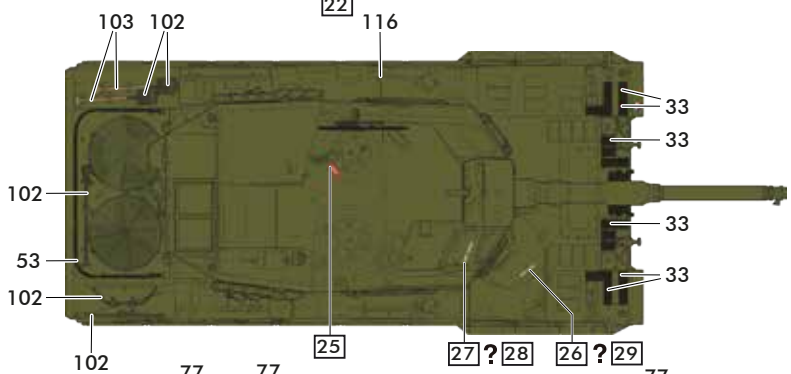
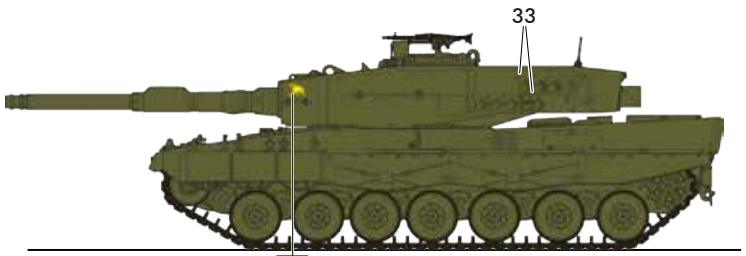
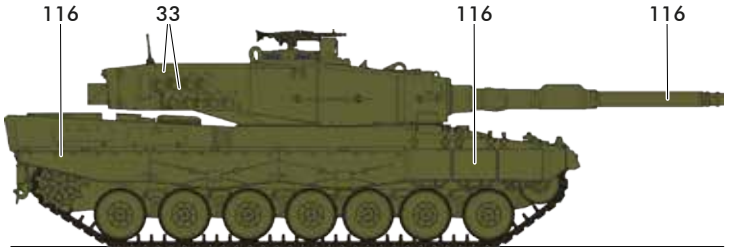
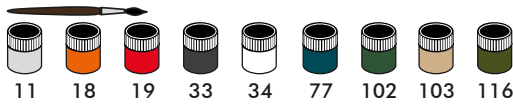

Austria: Österreichisches Bundesheer, Panzerbataillon 33, 1997-2015

Thanks to IPMS Austria for the support

VISITEZ NOTRE SITE WEB ET NOTRE BOUTIQUE EN LIGNE !

VISIT OUR WEBSITE AND ONLINESHOP!

BESUCHE UNSERE WEBSITE UND ONLINESHOP!



DOWNLOAD
INSTRUCTIONS



ORDER
SPARE
PARTS

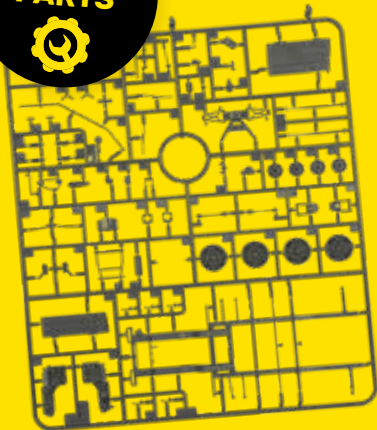

SHOP
ONLINE



V-190526

Heller Hobby GmbH | Erlenbacher Str. 3 | 42477 Radevormwald | Germany

+49 (0) 2195-92773-0 | www.heller.fr | info@heller.fr

[instagram.com/heller.fr](https://www.instagram.com/heller.fr) | [facebook.com/heller.fr](https://www.facebook.com/heller.fr)