

GOLDEN HIND



80829

F Sous le règne d'Elizabeth I, la Grande-Bretagne commence à créer ses propres routes de commerce maritime. Un de ces voyages fut monté dans le plus grand secret, sous couvert d'un voyage en Egypte, par Francis Drake. Le 13 Décembre 1577, cinq voiliers quittèrent Plymouth à destination « d'Alexandrie » (le Pélican, l'Elisabethan, le Marigold, le Swan et le Benedict). En pleine mer, les cinq navires connurent des fortunes diverses (naufrages et égarement). C'est une fois dans le Pacifique, passé le Détroit de Magellan que Drake pour parfaire le maquillage de sa mission, transforma le Pélican en Golden-Hind. Les trois ans qui suivirent ne furent que raids et abordages, au bénéfice de Drake et de ses « Pirates ».

GB During the reign of Elizabeth I, England began to establish its own maritime trade routes. One of these voyages was organized in the greatest secrecy, under the cover of a voyage to Egypt, by Francis Drake. On the 13th December 1577, five sailing ships left Plymouth, bound for "Alexandria" (the Pelican, the Elisabethan, the Marigold, the Swan and the Benedict). Once on the high seas, the five ships met with varied destinies (shipwrecks and loss at sea). It was not until he reached the Pacific, beyond the Straights of Magellan, that Drake, in order to perfect the disguise of his mission, rechristened the Pelican the Golden-Hind. The following three years were a series of raids and grappling, to the profit of Drake and his "Pirates".

D Während der Regierungszeit von Elizabeth I. begann England, eigene Seehandelsrouten einzurichten. Eine dieser Reisen wurde unter dem Deckmantel einer Reise nach Ägypten von Francis Drake, unter größter Geheimhaltung organisiert. Am 13. Dezember 1577 verließen fünf Segelschiffe Plymouth und fuhren nach „Alexandria“ (Pelican, Elisabethan, Marigold, Swan und Benedict). Auf hoher See trafen die fünf Schiffe auf unterschiedliche Schicksale (Schiffswracks und Verluste auf See). Erst als er den Pazifik jenseits der Magellanstraße erreichte taufte Drake den Pelican in Goldenen Hind, um die Tarnung seiner Mission zu perfektionieren. In den folgenden drei Jahren gab es eine Reihe von Überfällen und Auseinandersetzungen zum Vorteil von Drake und seinen „Piraten“.

E Bajo el reinado de Isabel la, Gran Bretaña comienza a crear sus propias rutas de comercio marítimo. Uno de estos viajes fue montado con el mayor secreto, encubierto por un viaje a Egipto, por Francis Drake. El día 13 de diciembre de 1577, cinco veleros zarparon de Plymouth con destino a « Alejandría » (el Pelican, el Elisabethan, el Marigold, el Swan y el Benedict). En alta mar los cinco barcos conocieron suertes diversas (naufragios y extravíos). Fue una vez Llegado al Pacífico, cruzado el Estrecho de Magallanes, cuando Drake, para perfeccionar el maquillaje de su misión, transformó el Pelican en Golden-Hind. Durante los tres años que siguieron, se realizaron correrías y abordajes, en benéfico de Drake y de sus « Piratas ».













NL Tijdens het bewind van Elizabeth I begon Engeland met het opzetten van zijn eigen maritieme handelsroutes. Francis Drake organiseerde een van deze reizen in het grootste geheim, onder het mom van een reis naar Egypte. Vijf zeilschepen verlieten Plymouth op 13 december 1577, met bestemming "Alexandria" (de Pelican, de Elisabethan, de Marigold, de Swan en de Benedict). Pas toen hij de Stille Oceaan bereikte en de Straat van Magellan voorbij was, gaf Drake de Pelican een nieuwe naam, de Golden-Hind, om de dekmantel van zijn missie te perfectioneren.

I Durante il regno di Elisabetta I, l'Inghilterra iniziò a stabilire le proprie rotte commerciali marittime. Uno di questi itinerari fu organizzato sotto le spoglie di un viaggio in Egitto da Francis Drake, nel più grande segreto. Il 13 dicembre 1577, cinque velieri partirono da Plymouth verso "Alessandria" (Pelican, Elisabethan, Marigold, Swan e Benedict). Solo quando raggiunse l'Oceano Pacifico oltrelo Stretto di Magellano, Drake ribattezzò il Pelican Golden Hind (in italiano "Cerva d'Oro) per perfezionare il mimetismo della sua missione.







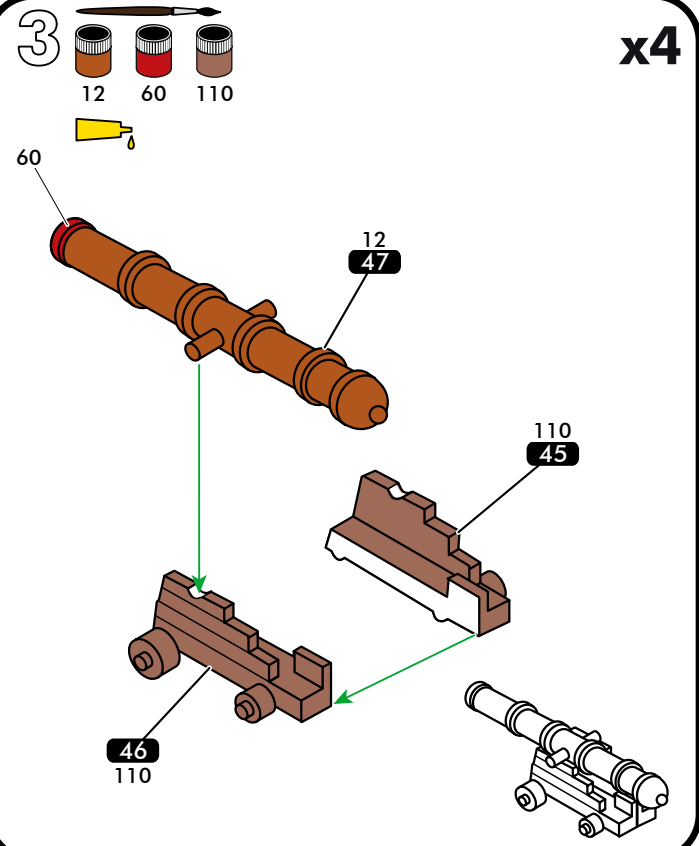
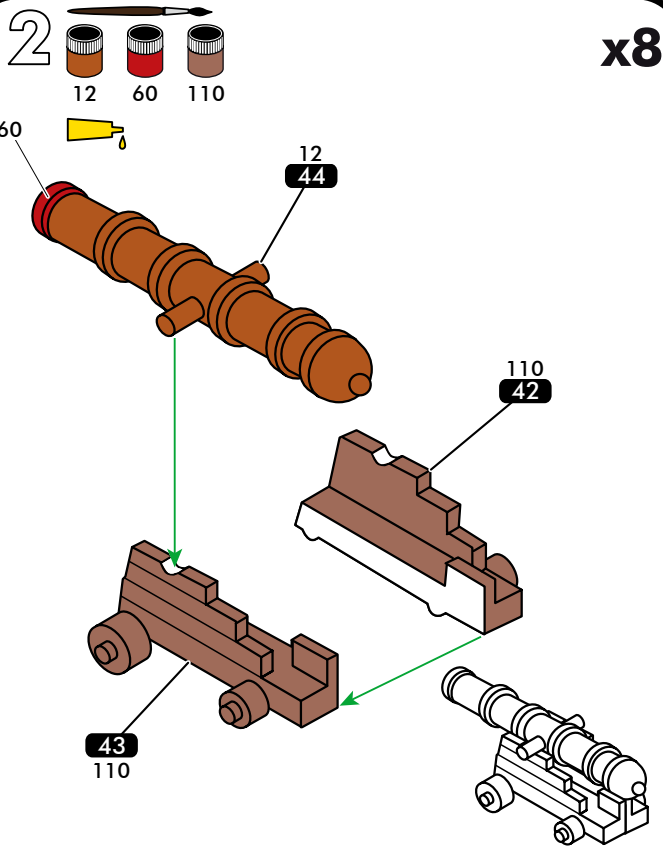
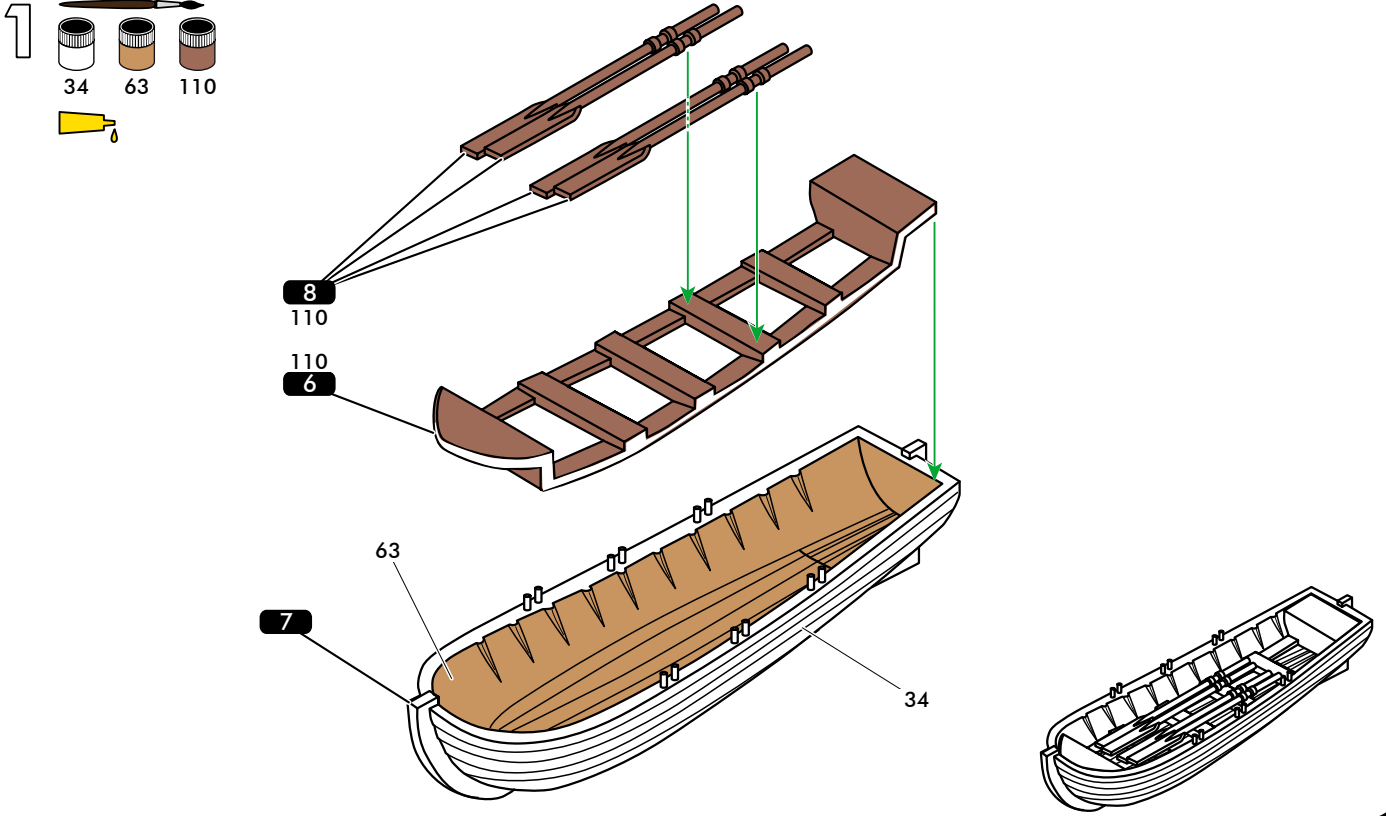

<p>2 Numéro de phase Step number Schrittnummer Número de fase</p>	<p>56 Référence de couleur Colour reference no Farbangabe Referencia de color</p>
<p>37 Numéro de pièce Part number Teilenummer Número de pieza</p>	<p>6 Numéro de decal Decal number Nummer von Abziehbild Número de calcomanía</p>

PEINTURES ESSENTIELLES / ESSENTIAL PAINTS

Disponibles séparément chez votre revendeur de maquettes. / Available separately at your local hobby shop.

- | | | | | | | |
|---|--|--|---|---|---|--|
| 
11
Argent
Silver
Silber | 
12
Cuivre jaune
Copper
Kupfer | 
16
Or
Gold
Gold | 
24
Jaune entraînement mat
Matt trainer yellow
Matt-Trainer-Gelb | 
25
Bleu brillant
Gloss blue
Glänzend -Blau | 
27
Gris mer mat
Matt sea grey
Matt-Seegrau | 
33
Noir mat
Matt black
Mattschwarz |
| 
34
Blanc mat
Matt white
Mattweiss | 
60
Ecarlate mat
Matt scarlet
Matt-Scharlachrot | 
63
Sable mat
Matt sand
Matt-Sand | 
71
Chêne satiné
Satin oak
Satin-Eichgrün | 
101
Vert moyen mat
Matt mid green
Matt-Mittelgrün | 
110
Bois naturel mat
Matt natural wood
Matt-Naturholz | |



-  110
-  101
-  63
-  60
-  34
-  33
-  25
-  24
-  16

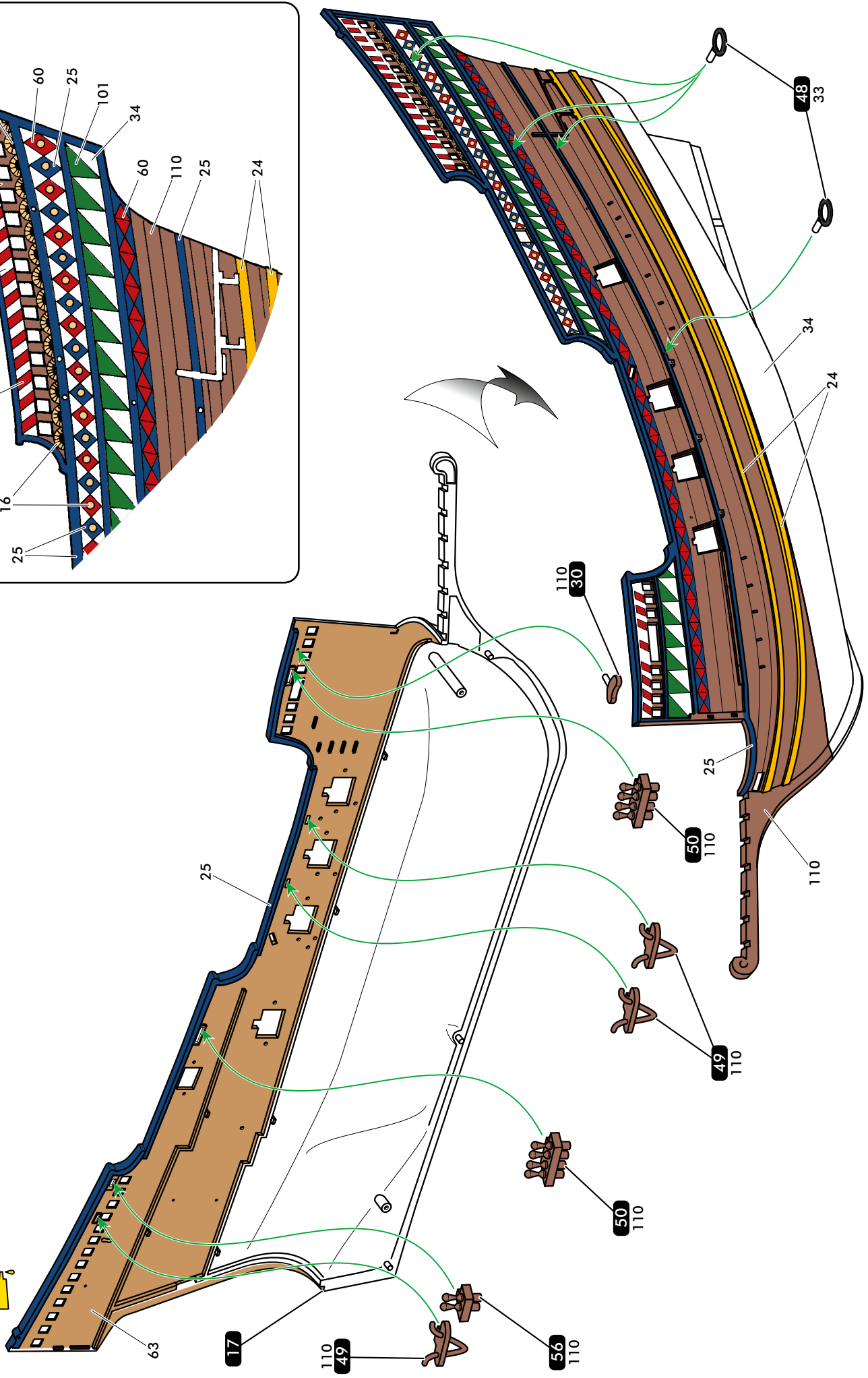
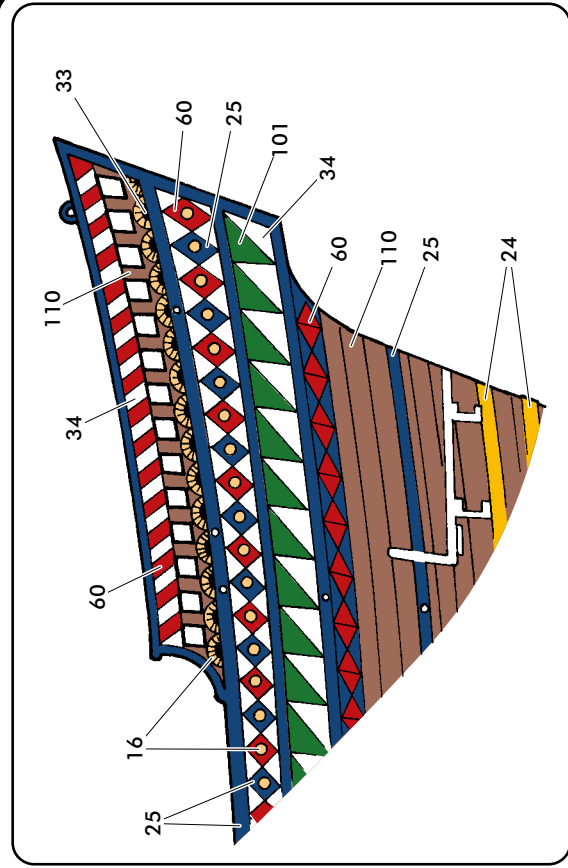

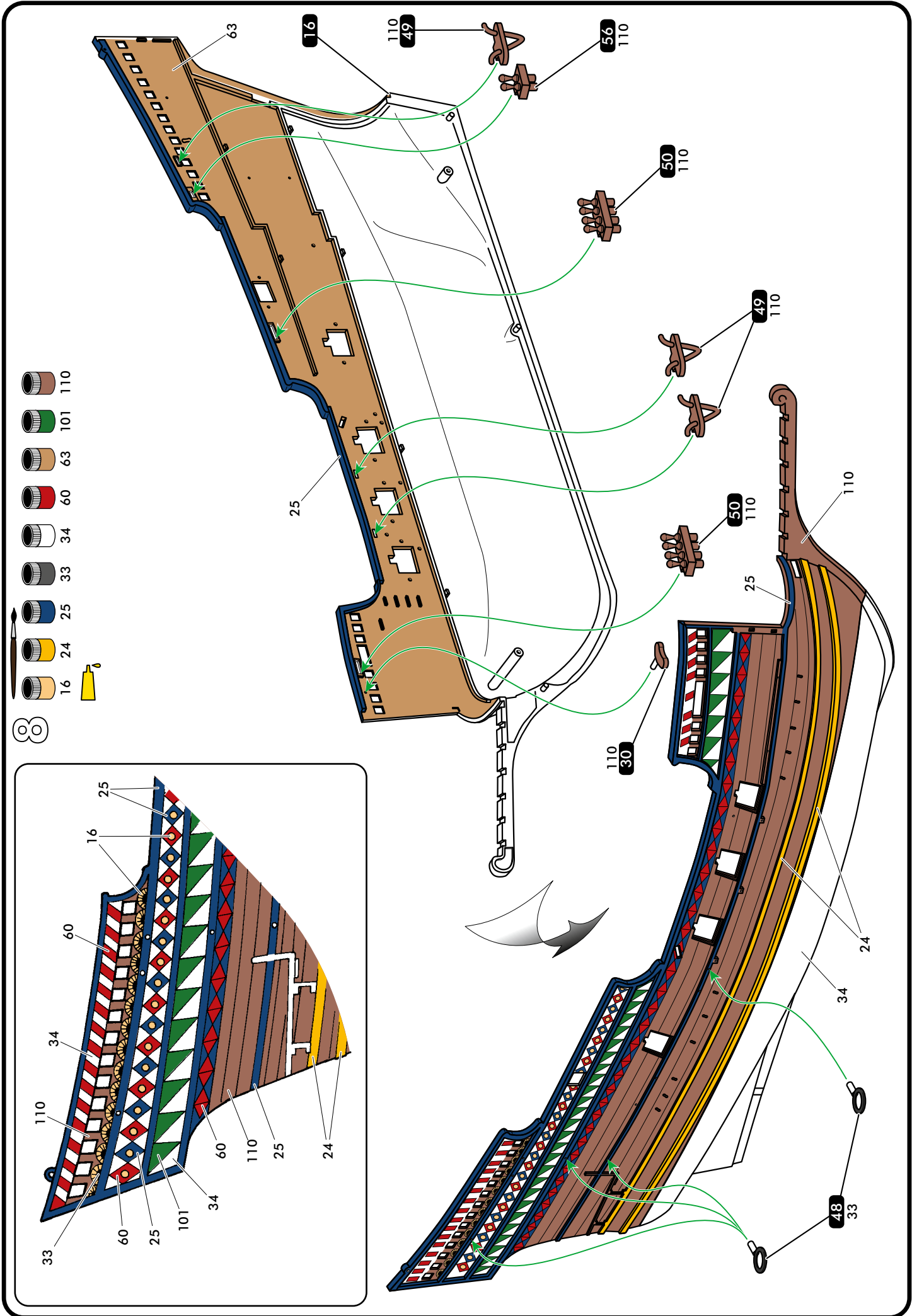

- 9
- 27
- 33
- 63
- 110
- Fi
Thread
Garn
Hilo
Ø 0,3 mm

9A **x104**

110 121

33

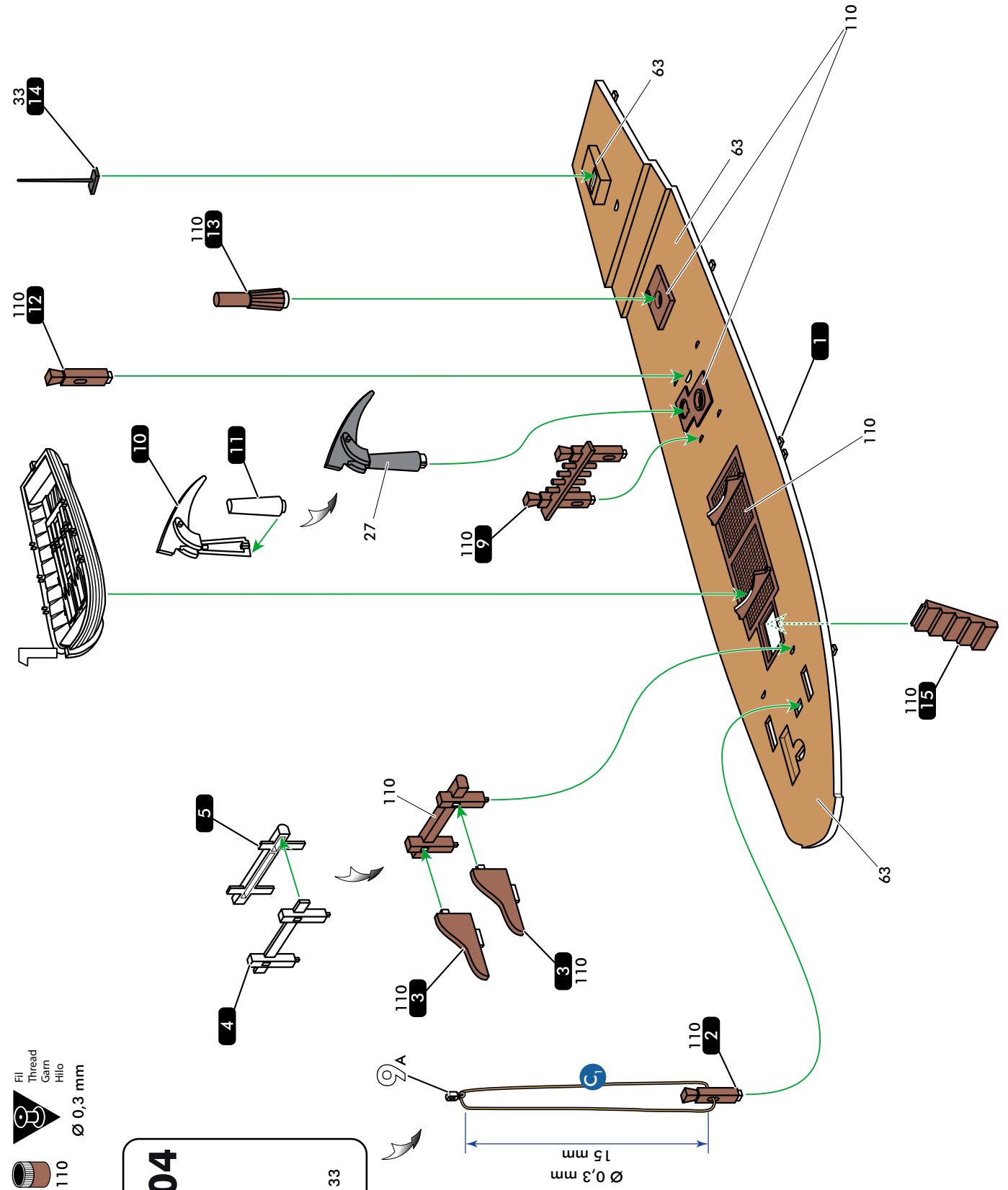

10

Fil Thread Garn Hilo



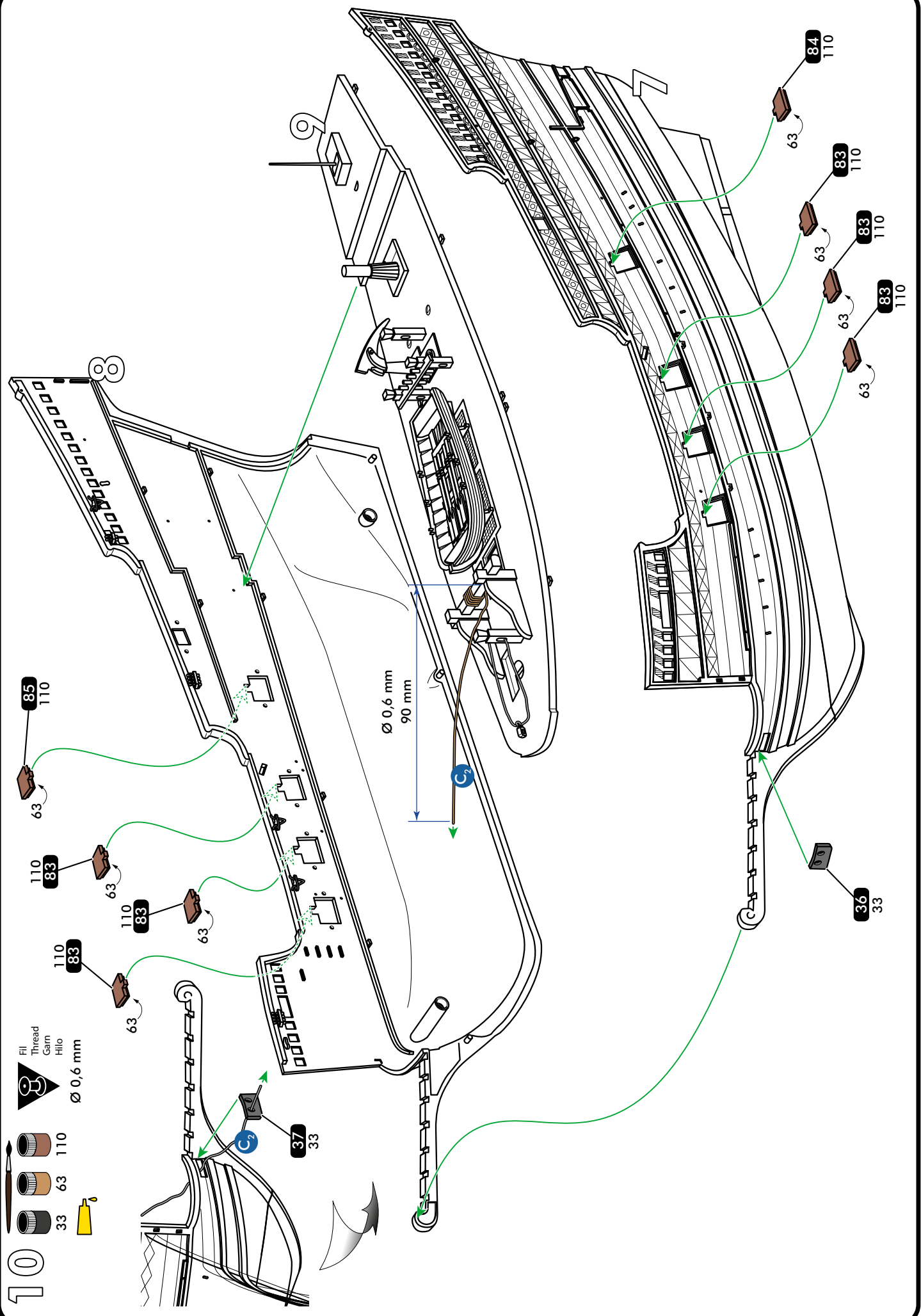
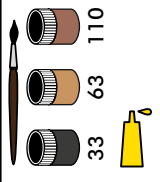

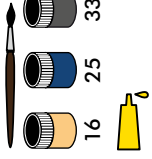

 Ø 0,6 mm

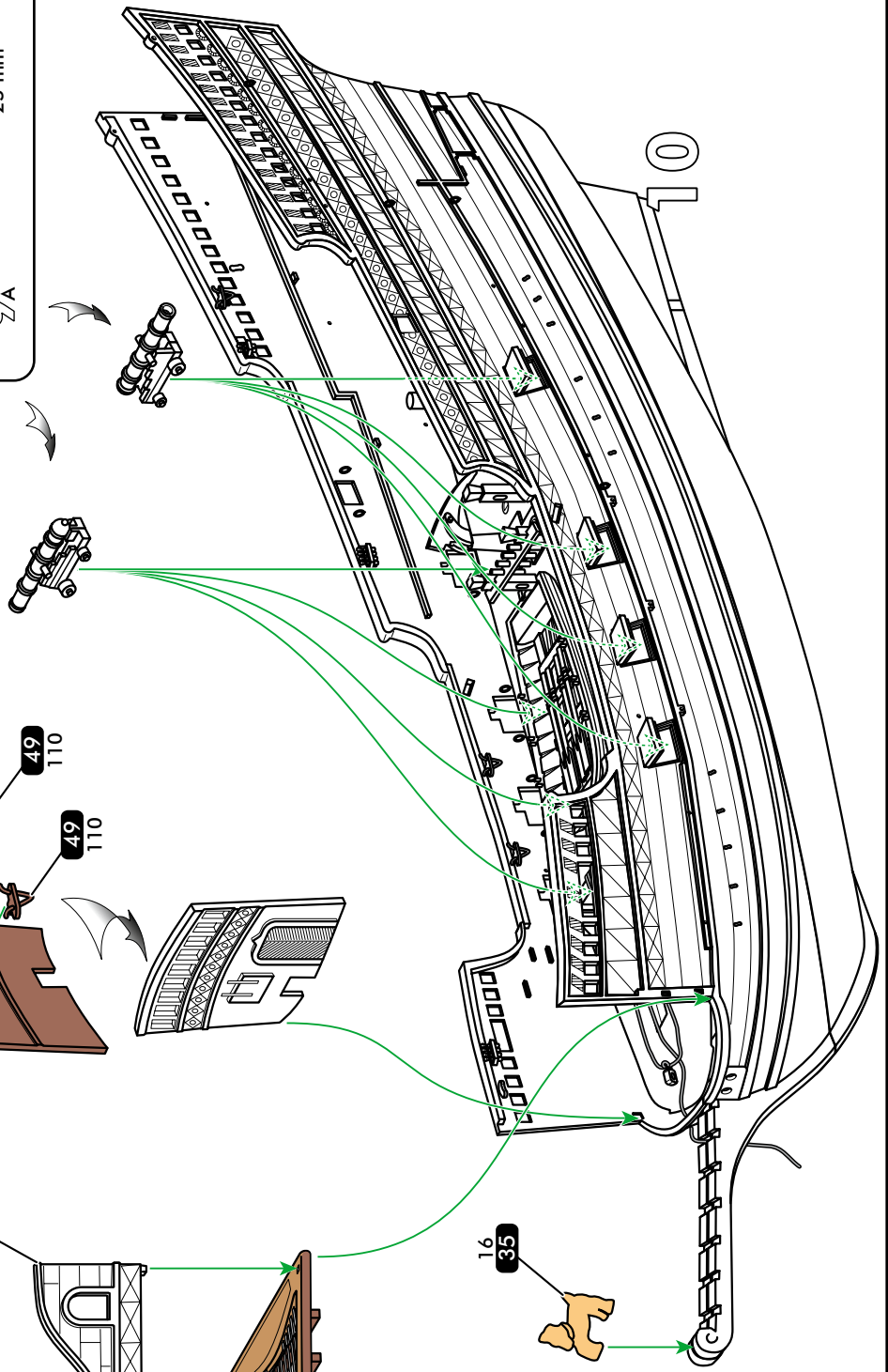
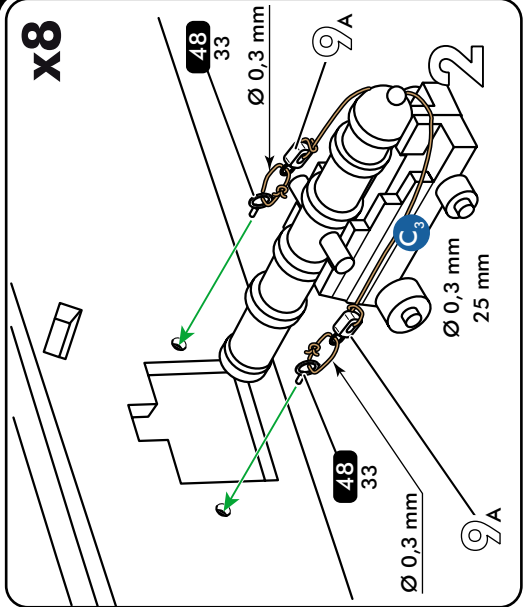
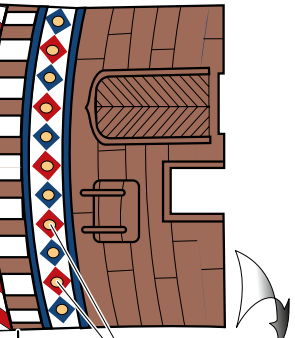
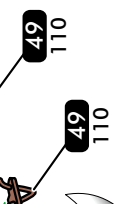
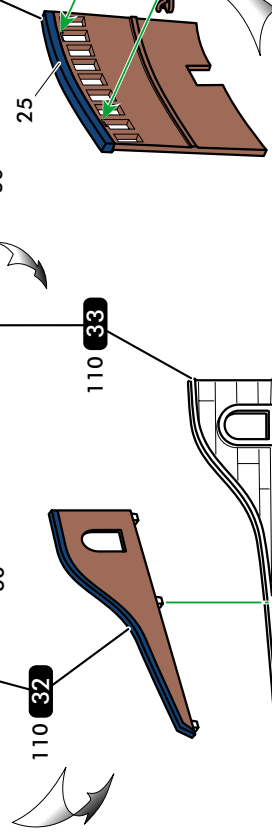
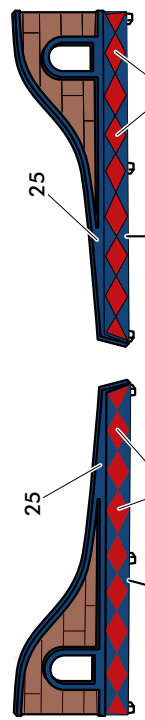



- 16 25 33 34 60 63 110
- Fill Thread Garn Hilo
- Ø 0,3 mm



-  16
-  25
-  34
-  60
-  63
-  110
- 
 - Fill
 - Thread
 - Garn
 - Hilo
- \varnothing 0,6 mm
- \varnothing 0,3 mm

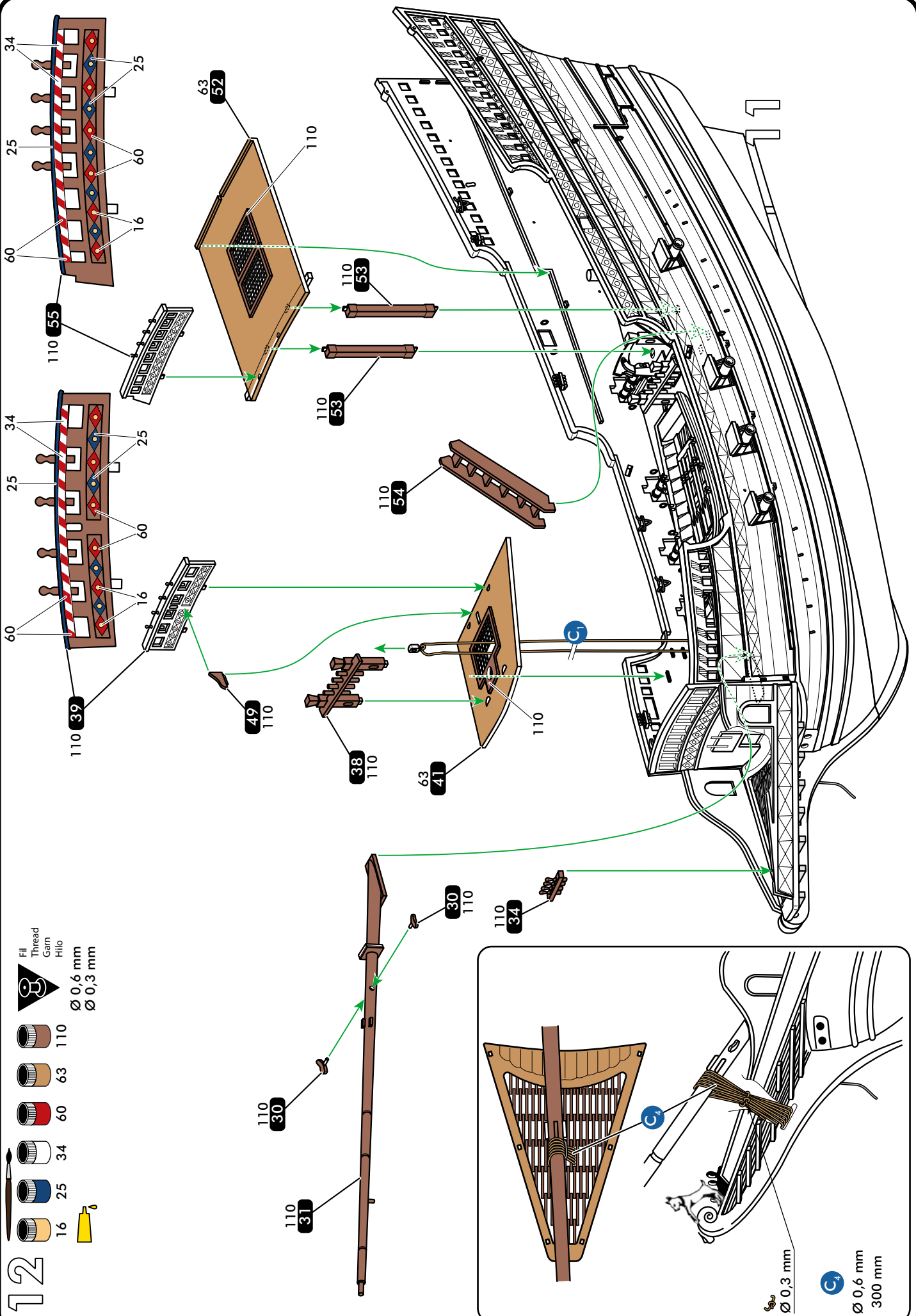







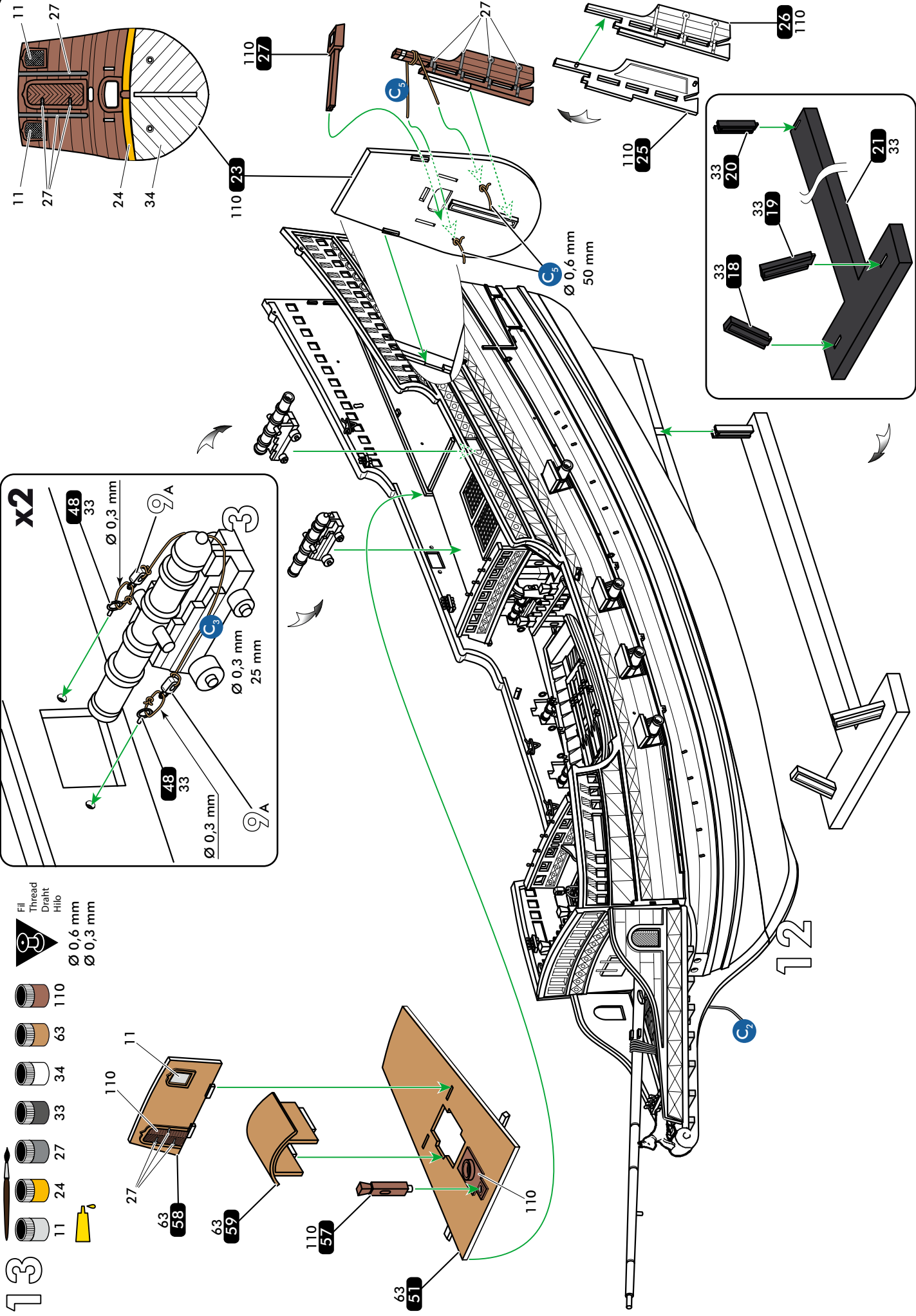
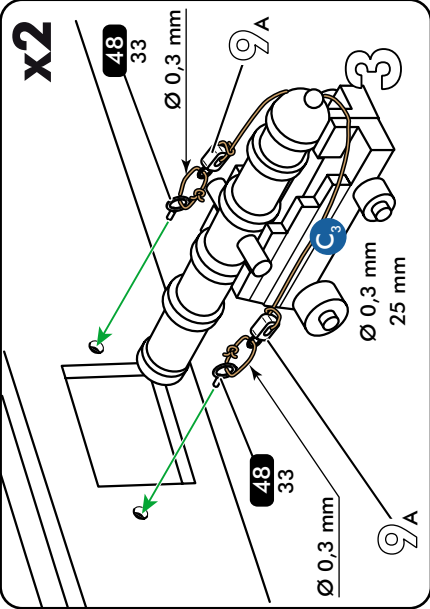





13

- 11
- 24
- 27
- 33
- 34
- 63
- 110

- Fill
- Thread
- Draht
- Hilo
- Ø 0,6 mm
- Ø 0,3 mm



-  16
-  16
-  25
-  33
-  34
-  60
-  63
-  110

-  Fill
-  Thread
-  Gain
-  Hilo
- $\varnothing 0,3 \text{ mm}$

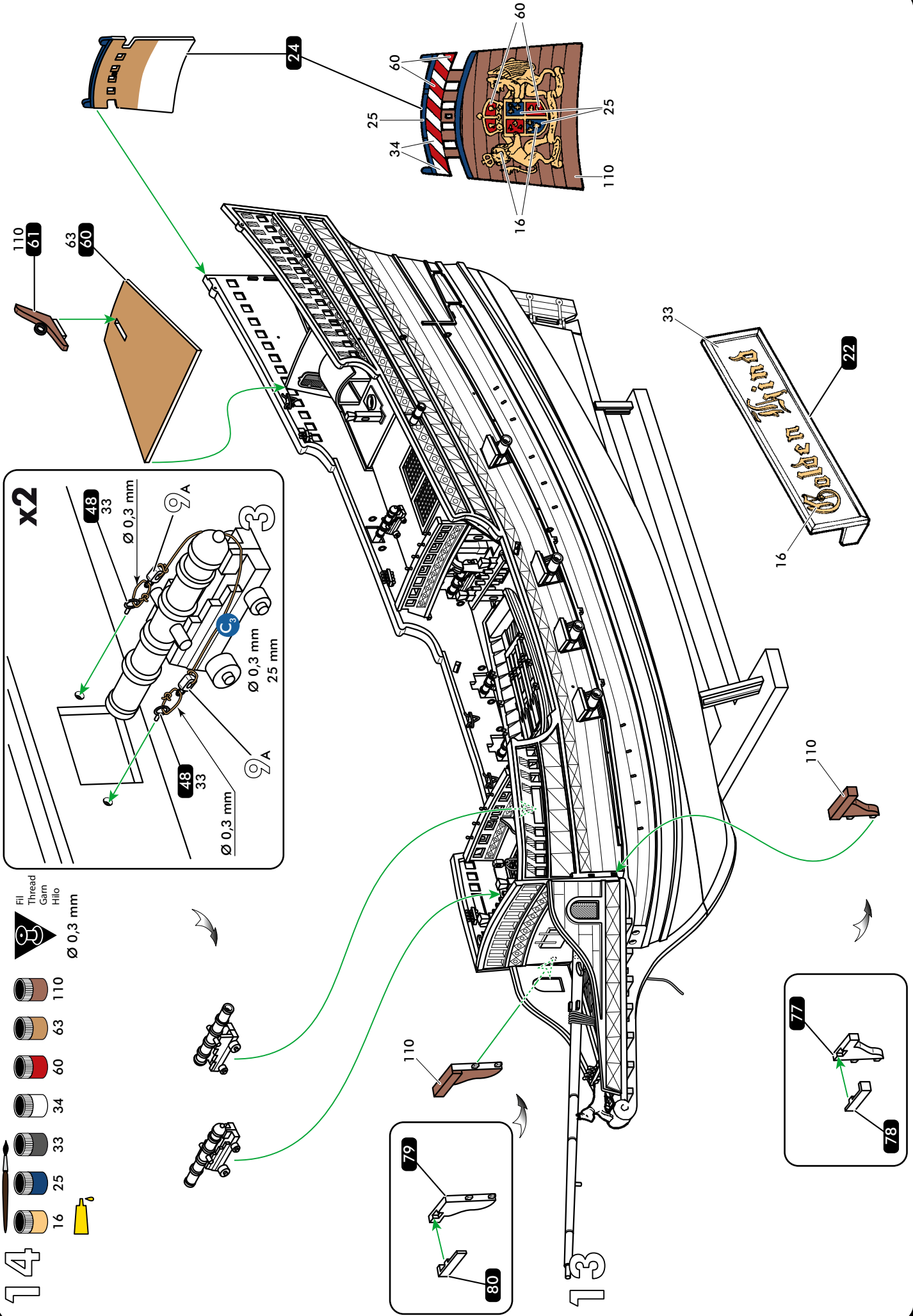
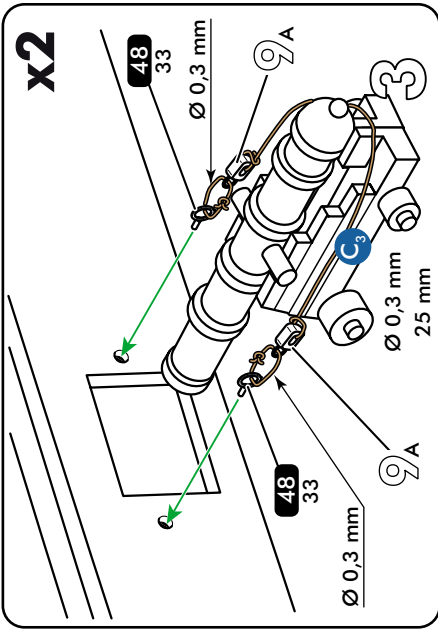

15

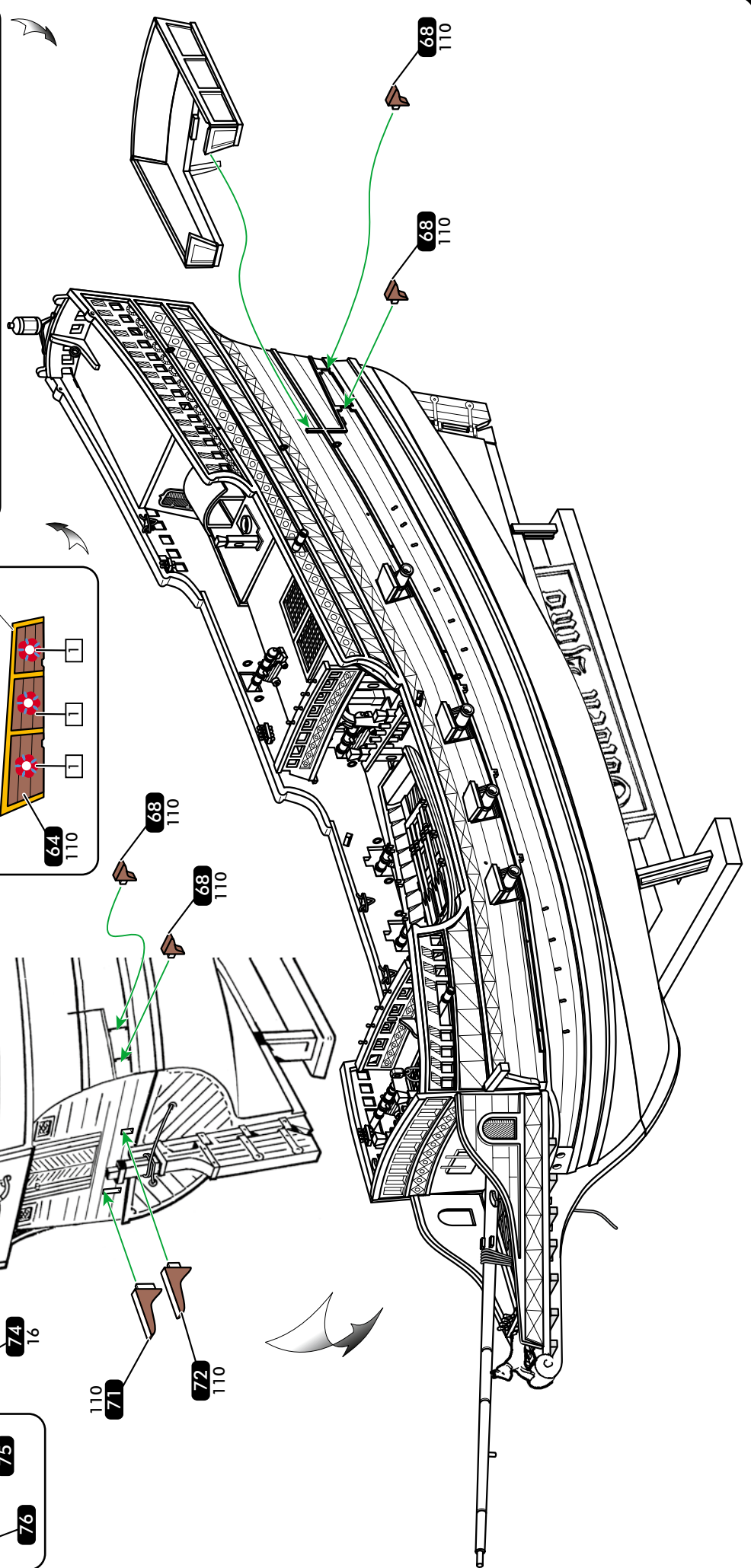
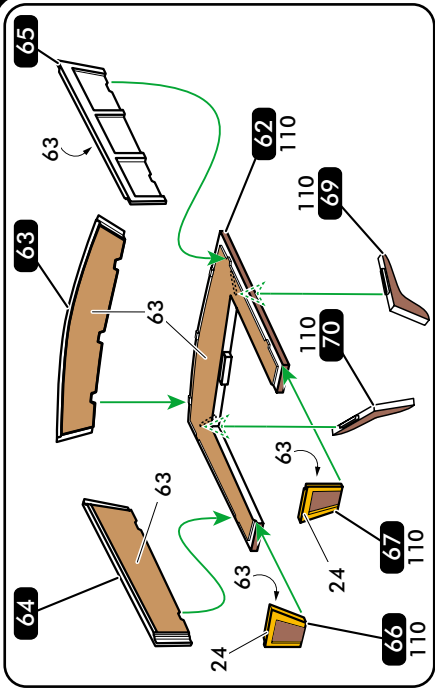
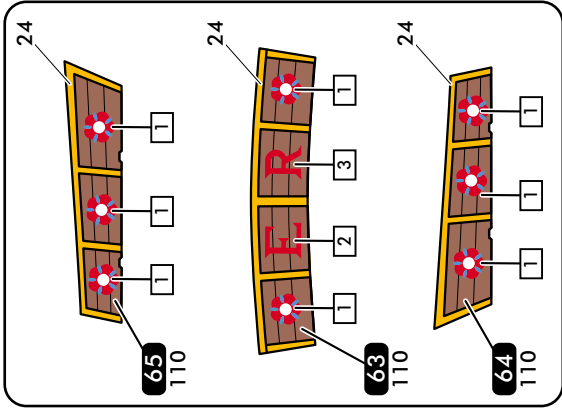
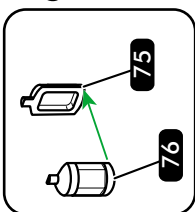
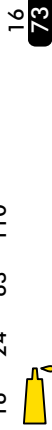
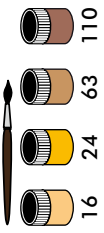

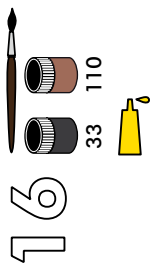

16

Fill
Thread
Gain
Hilo
Ø 0,6 mm

C₆ Ø 0,6 mm
C₇ Ø 0,6 mm

50 mm x2
15 mm

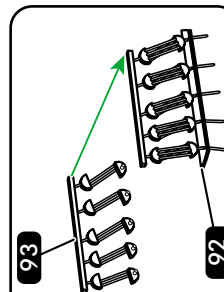
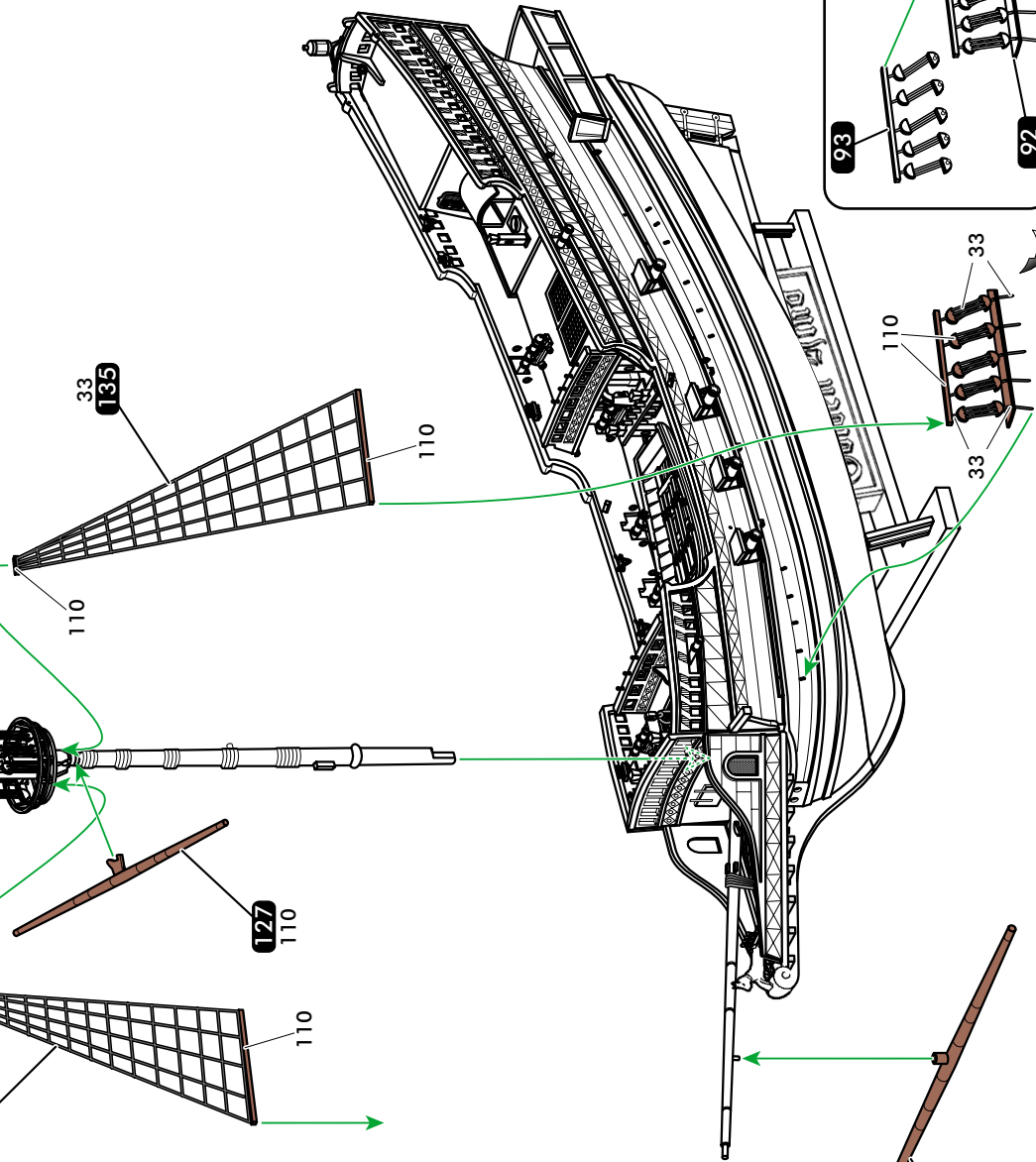
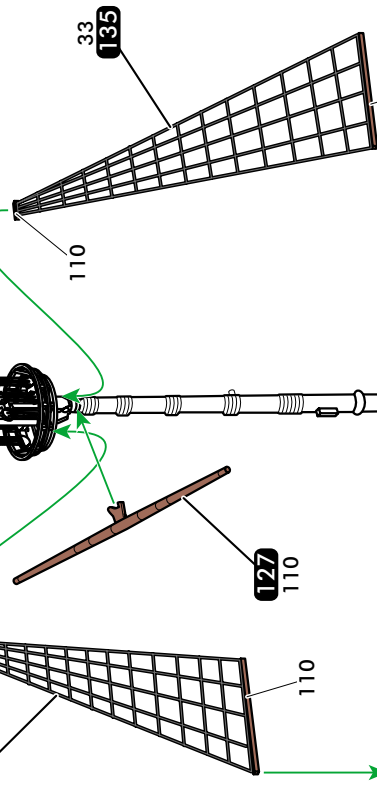
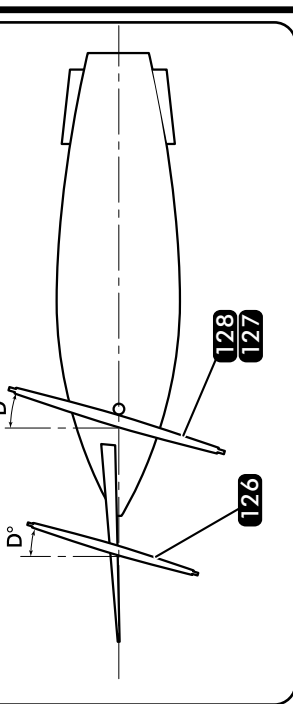
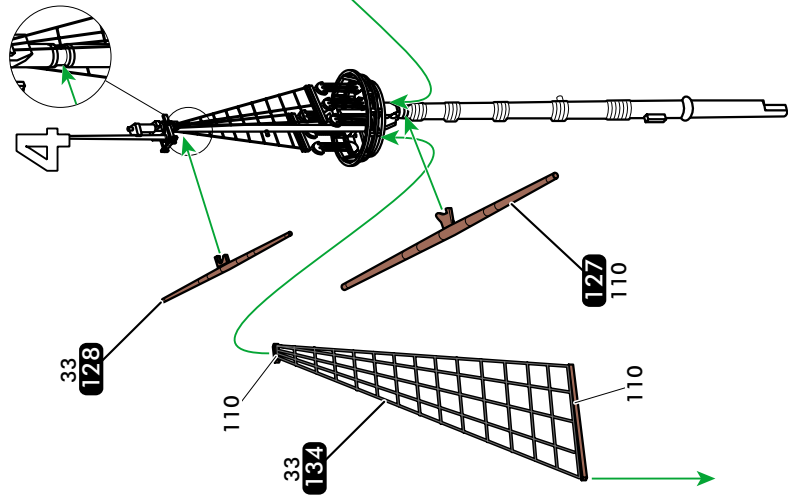
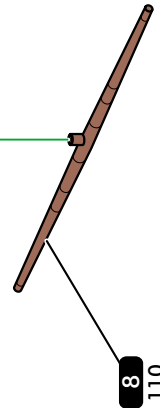
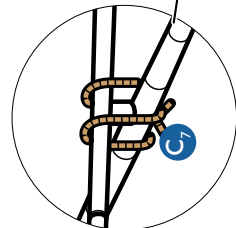
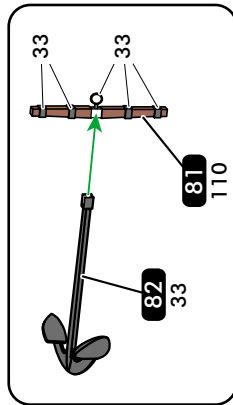
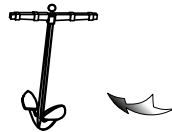
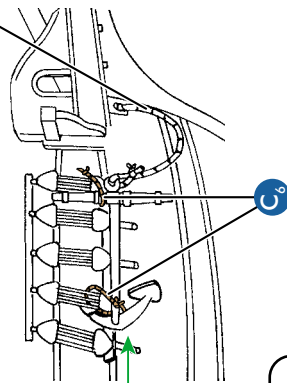
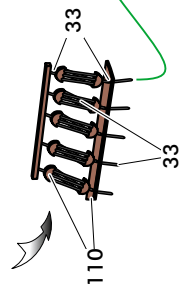
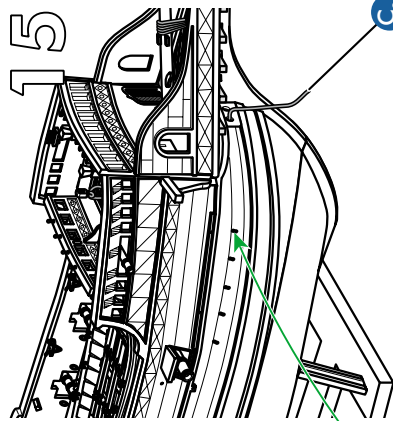
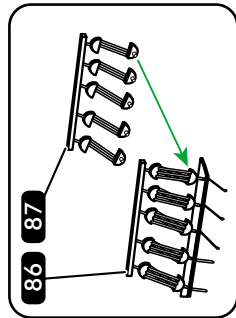

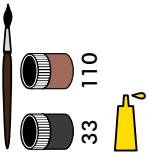

17
 Fil
 Thread
 Garn
 Hilo
 Ø 0,3 mm
 Ø 0,6 mm

Assemblage symétrique
 Symmetric assembly
 Simétrica Zusammenstellung
 Ensamblaje simétrico



- C₈** Ø 0,6 mm 240 mm
- C₉** Ø 0,6 mm 260 mm
- C₁₀** Ø 0,6 mm 190 mm
- C₁₁** Ø 0,6 mm 280 mm **x2**

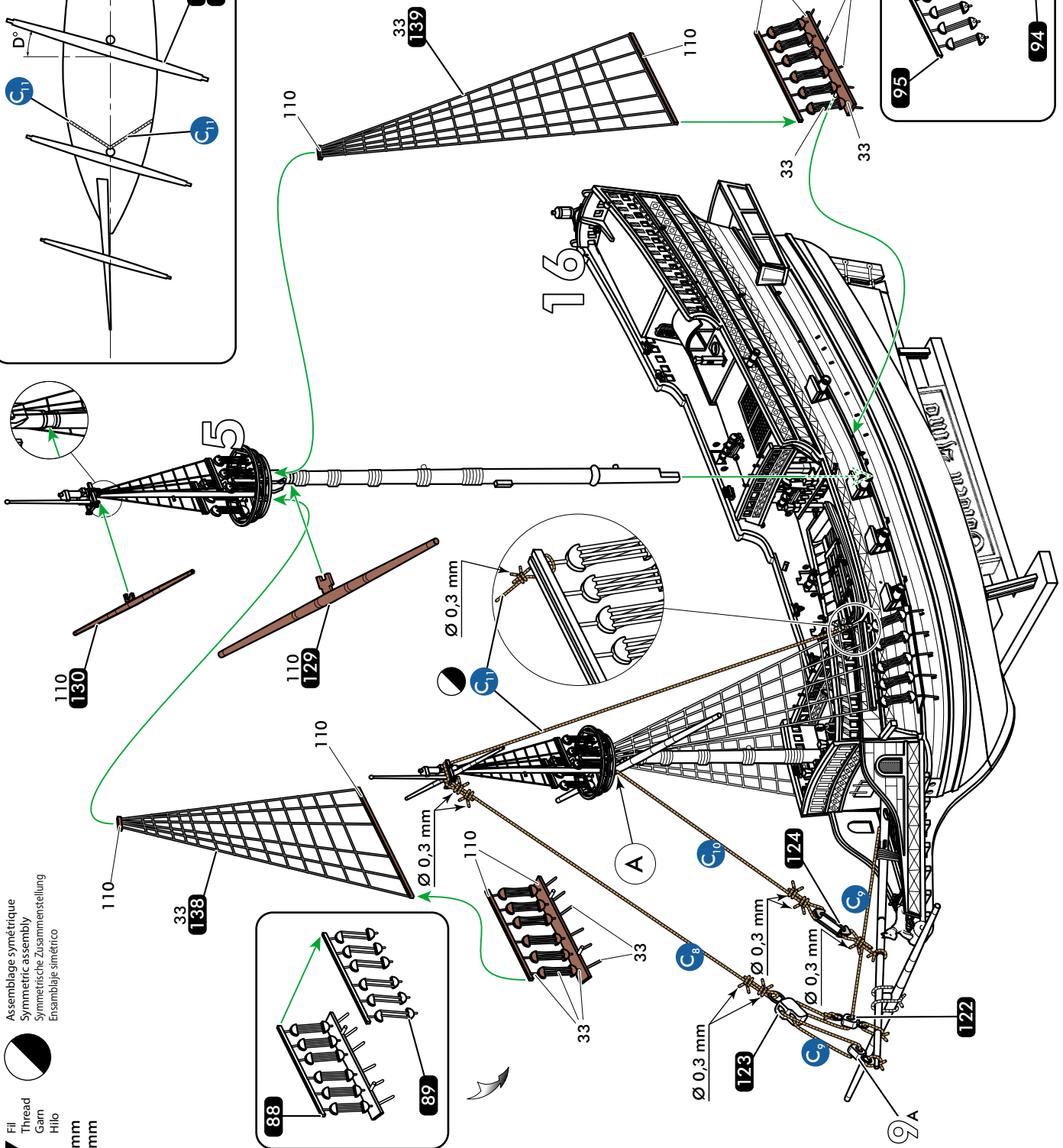
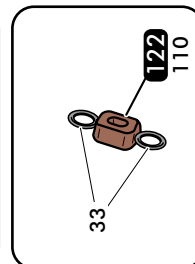
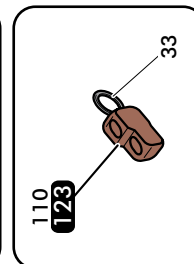
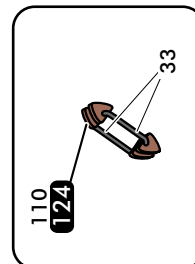
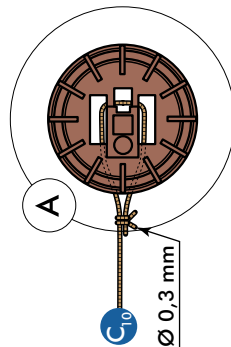
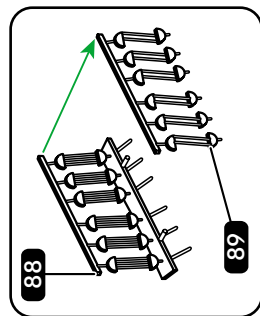
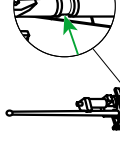
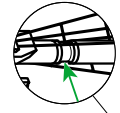
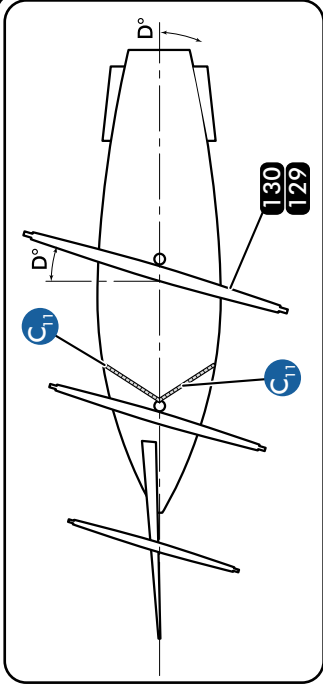

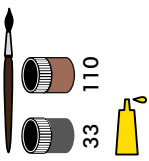

Fill
 Thread
 Gain
 Hilo
 Ø 0,3 mm
 Ø 0,6 mm

C₂ Ø 0,6 mm 220 mm
 C₃ Ø 0,6 mm 230 mm
 C₄ Ø 0,6 mm 290 mm **x2**

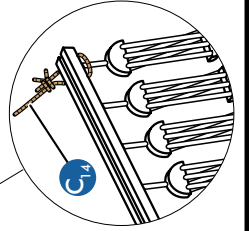
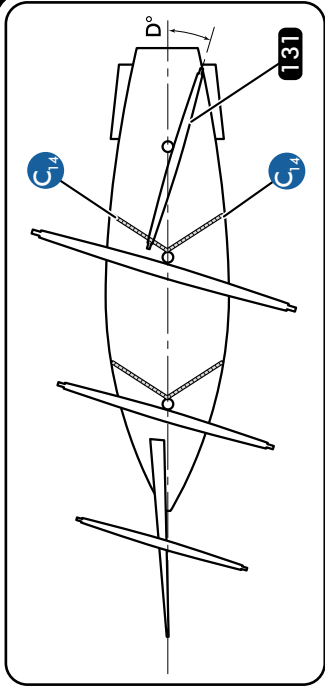
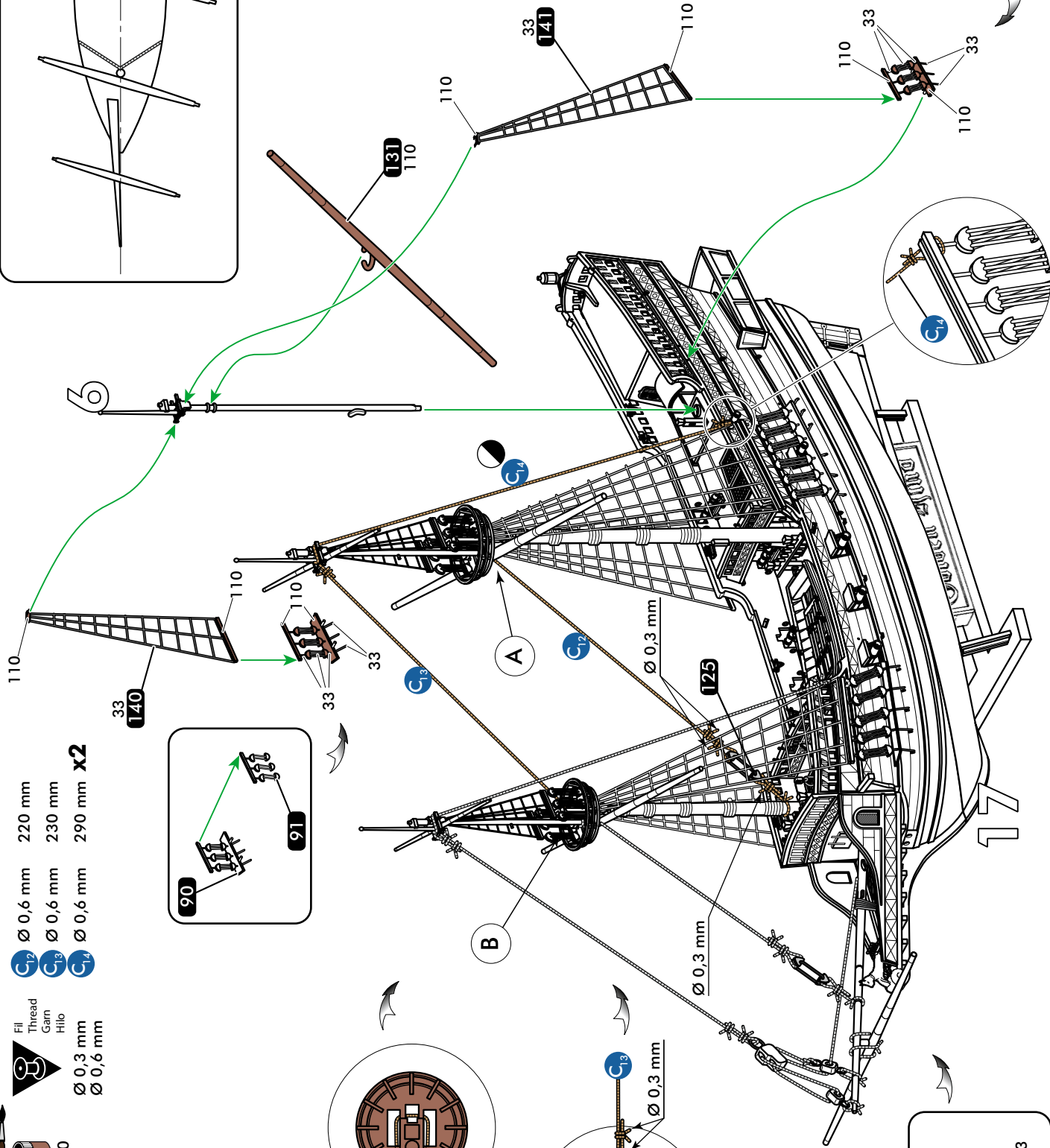
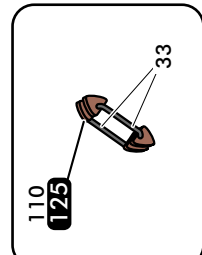
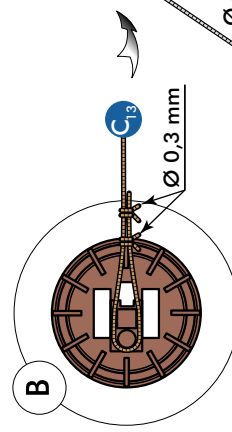
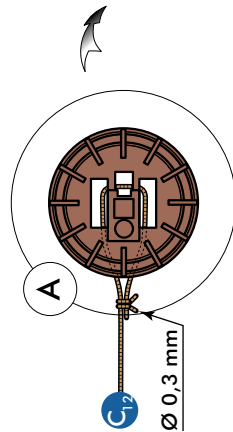
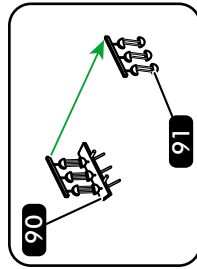

19

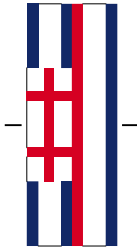
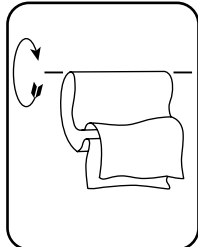
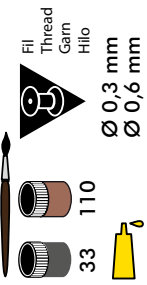

4



5

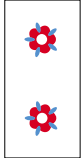
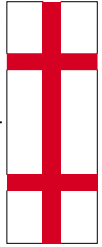

6

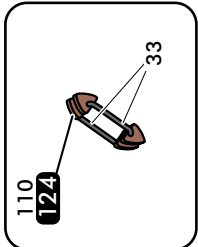
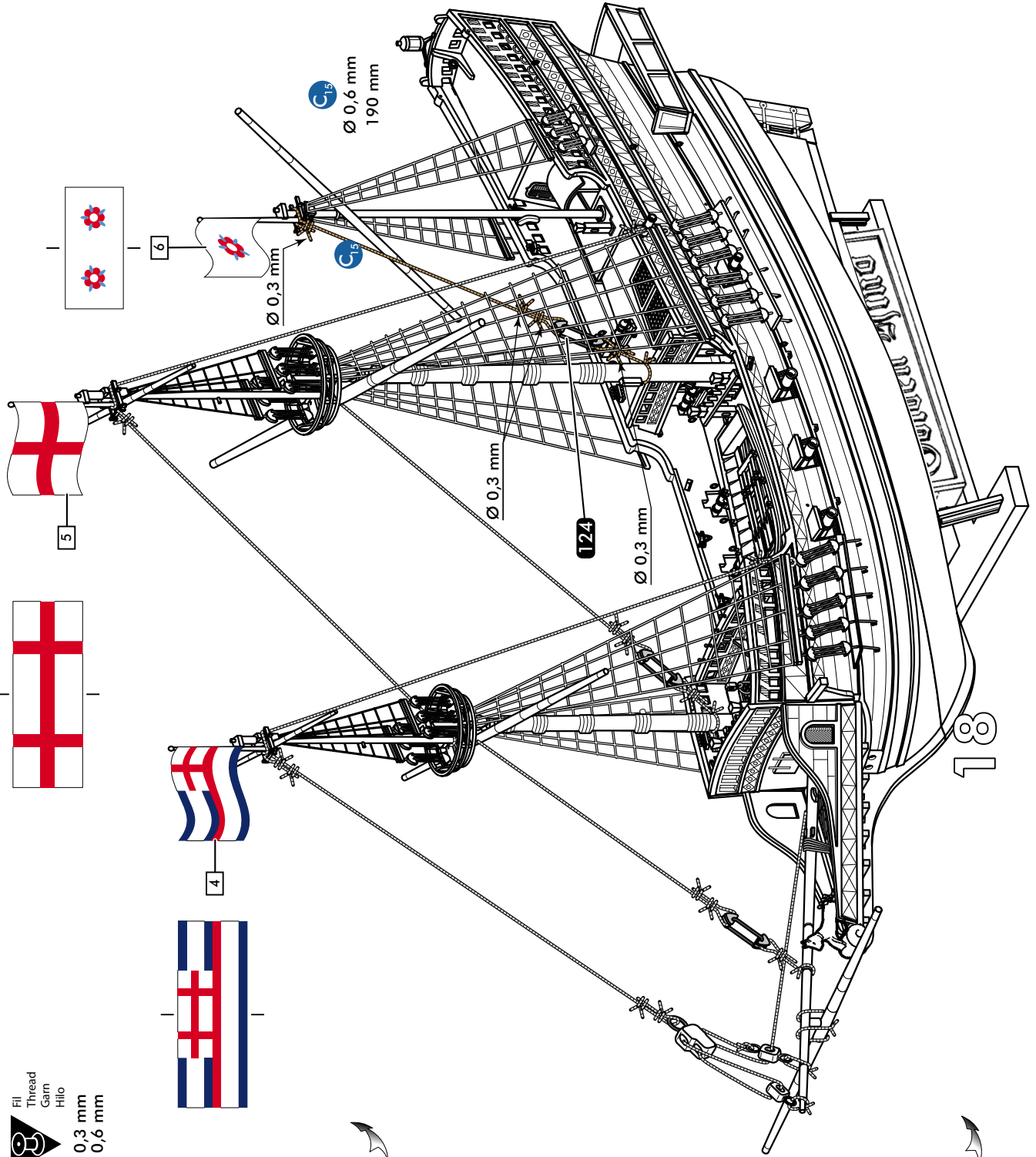

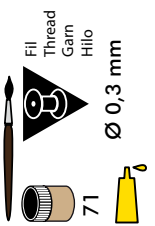

A B C D E F



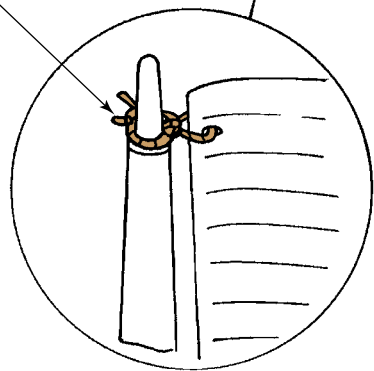
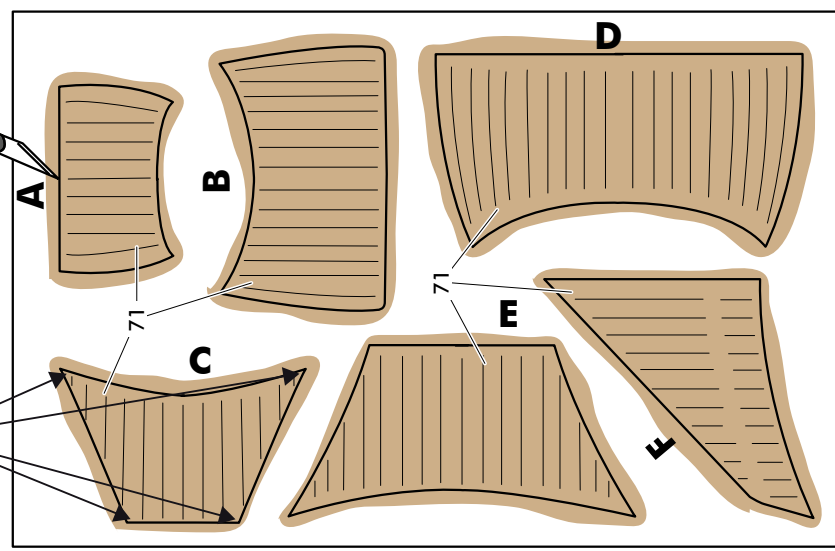
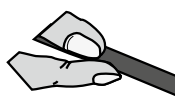

Ø 0,5 mm

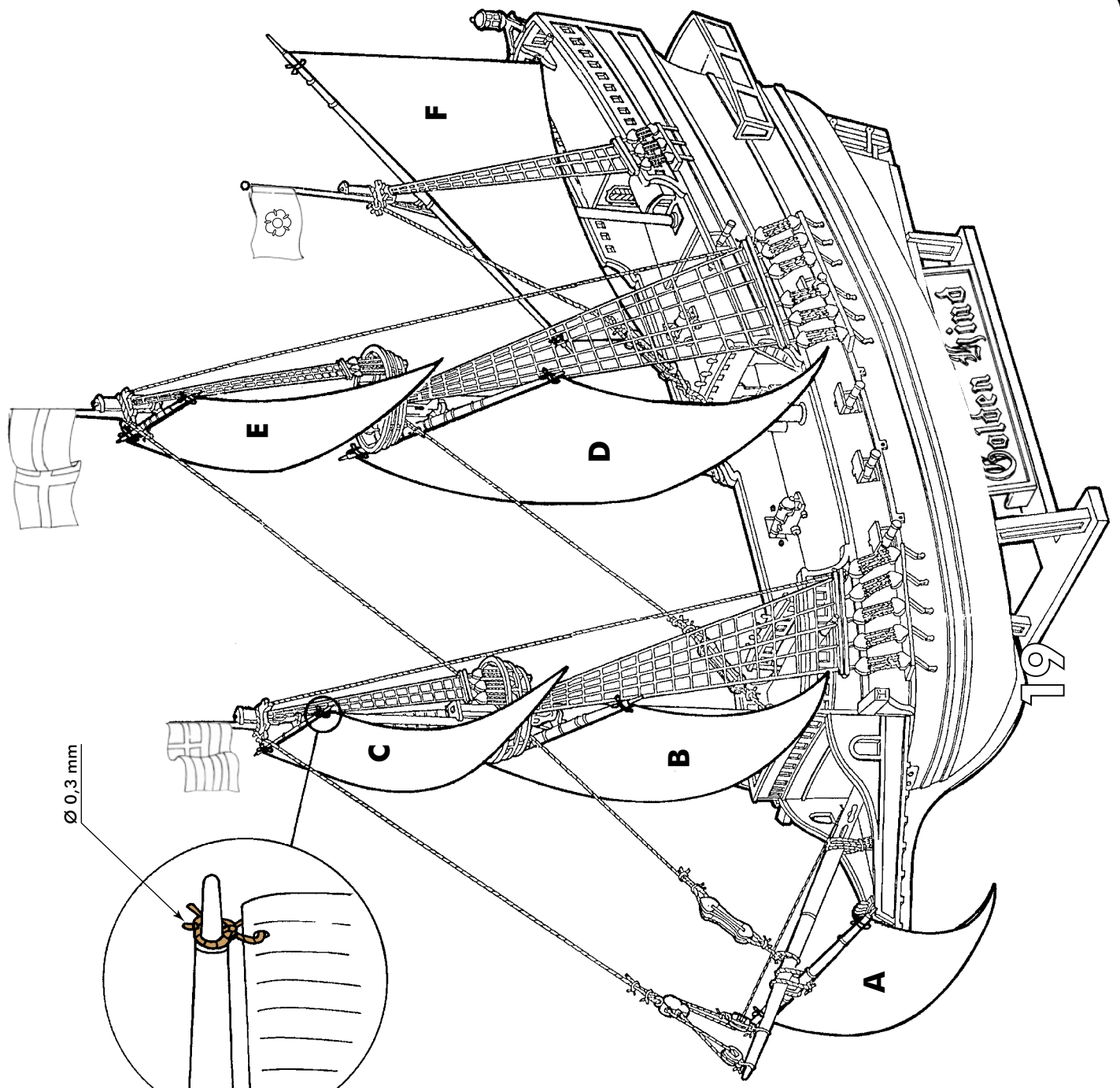

Ø 0,3 mm



21

-   33
-  110
- 
-  **Fill Thread Garn Hilo**
Ø 0,3 mm

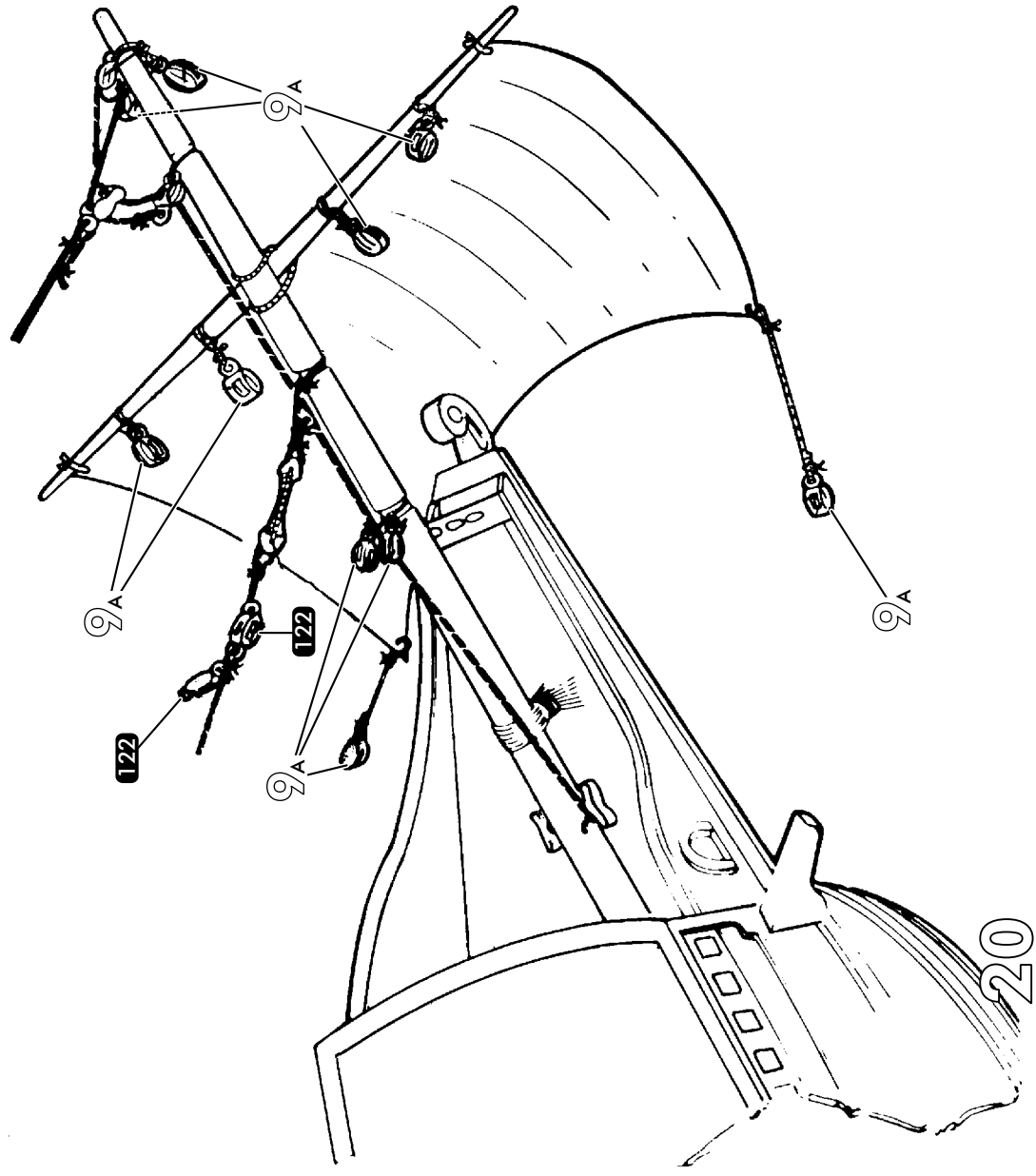

x2

33 122 110

Fill
Thread
Garn
Hilo
Ø 0,3 mm

- C₆ Ø 0,3 mm x2
- C₇ Ø 0,3 mm x2
- C₈ Ø 0,3 mm x2
- C₉ Ø 0,3 mm x2

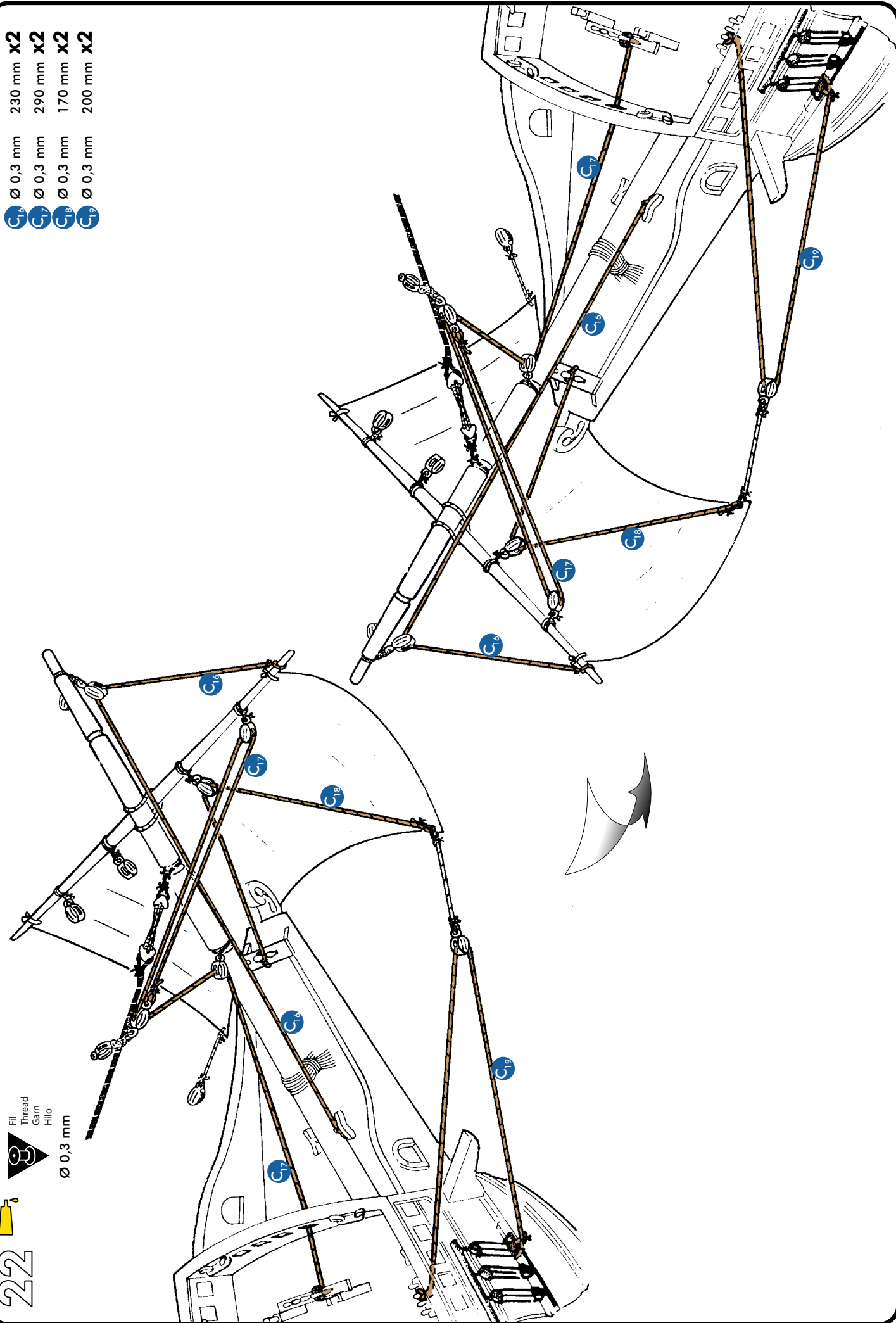

23

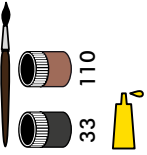

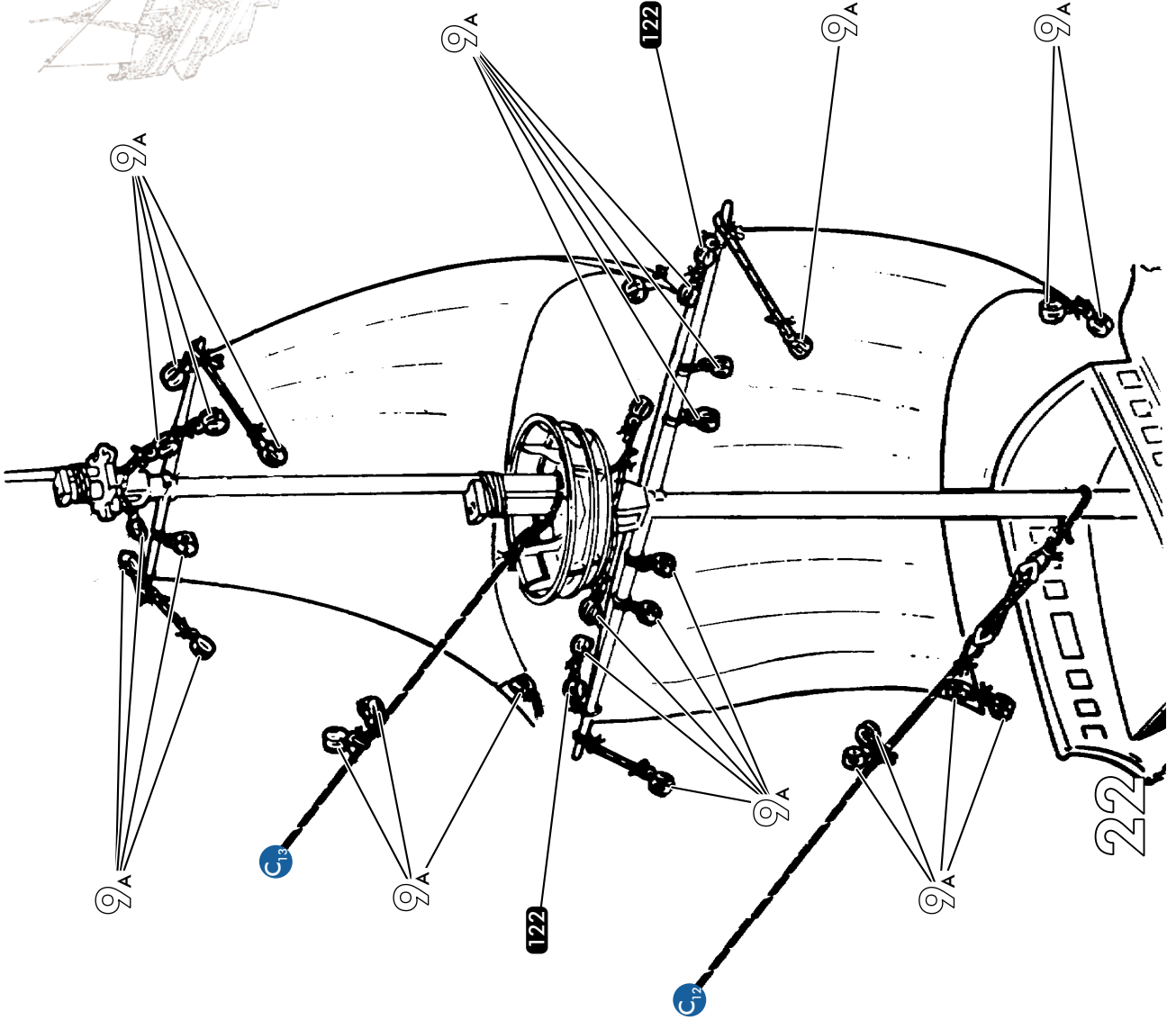
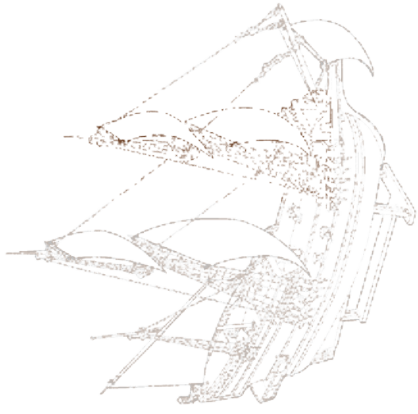

 Fill Thread
 Gain Hilo
 Ø 0,3 mm



x2

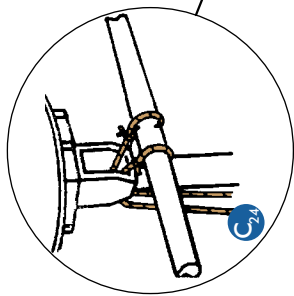

Fill
Thread
Garn
Hilo
Ø 0,3 mm



- C₂₀ Ø 0,3 mm x2
- C₂₁ Ø 0,3 mm x2
- C₂₂ Ø 0,3 mm x2
- C₂₃ Ø 0,3 mm x2
- C₂₄ Ø 0,3 mm x2
- C₂₅ Ø 0,3 mm x2
- C₂₆ Ø 0,3 mm x2
- 250 mm x2
- 230 mm x2
- 270 mm x2
- 280 mm x2
- 260 mm
- 170 mm x2
- 190 mm x2

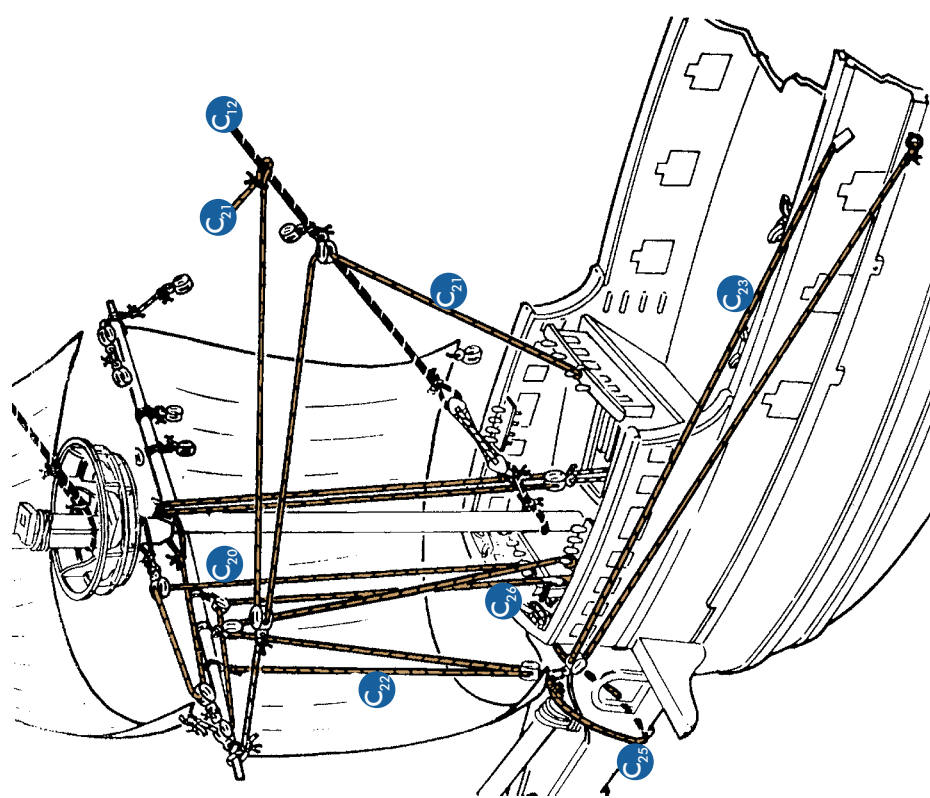
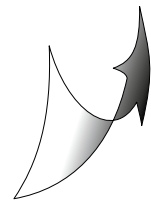
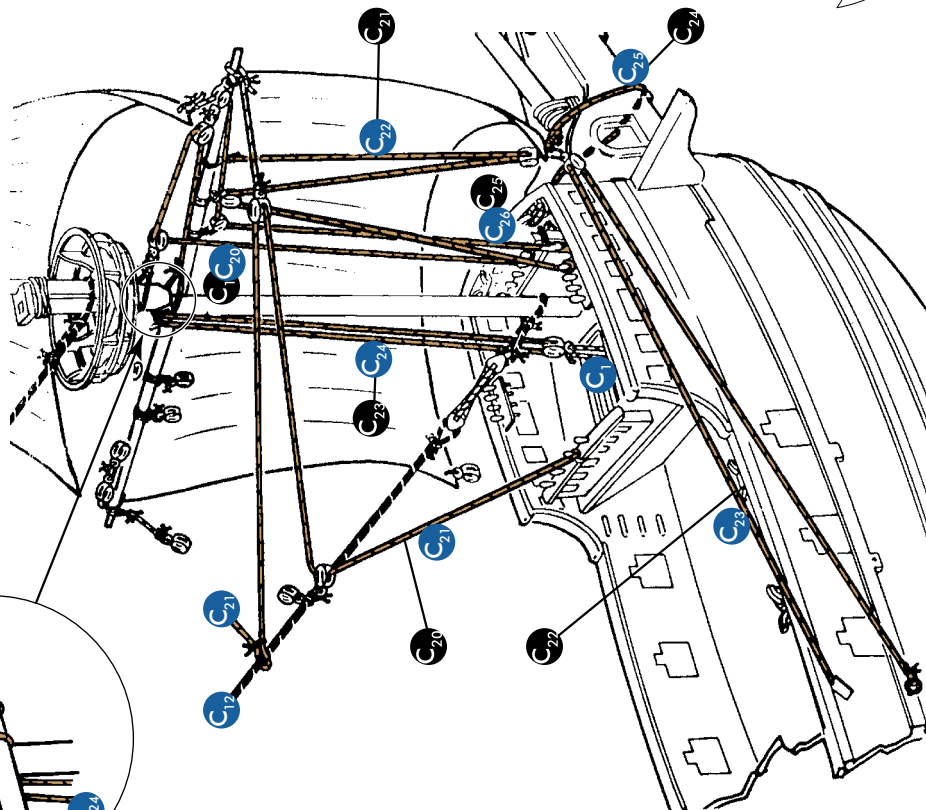



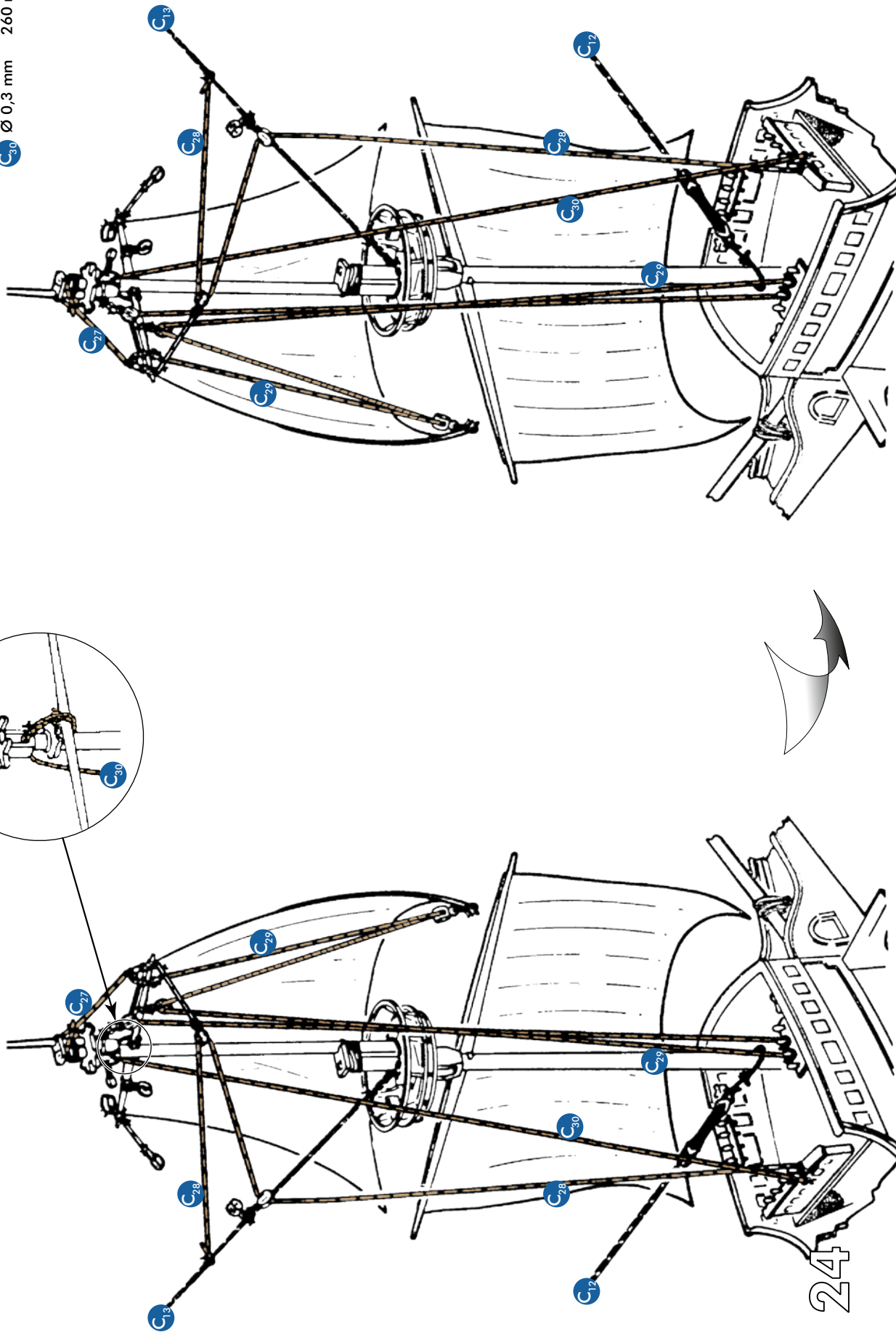
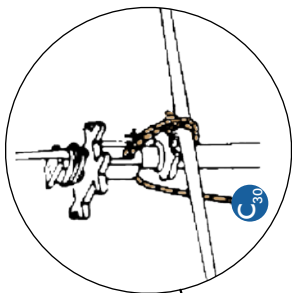

 Fil
 Thread
 Garn
 Hilo
 Ø 0,3 mm

- C₂₇ Ø 0,3 mm 290 mm **x2**
- C₂₈ Ø 0,3 mm 300 mm **x2**
- C₂₉ Ø 0,3 mm 370 mm **x2**
- C₃₀ Ø 0,3 mm 260 mm **x2**

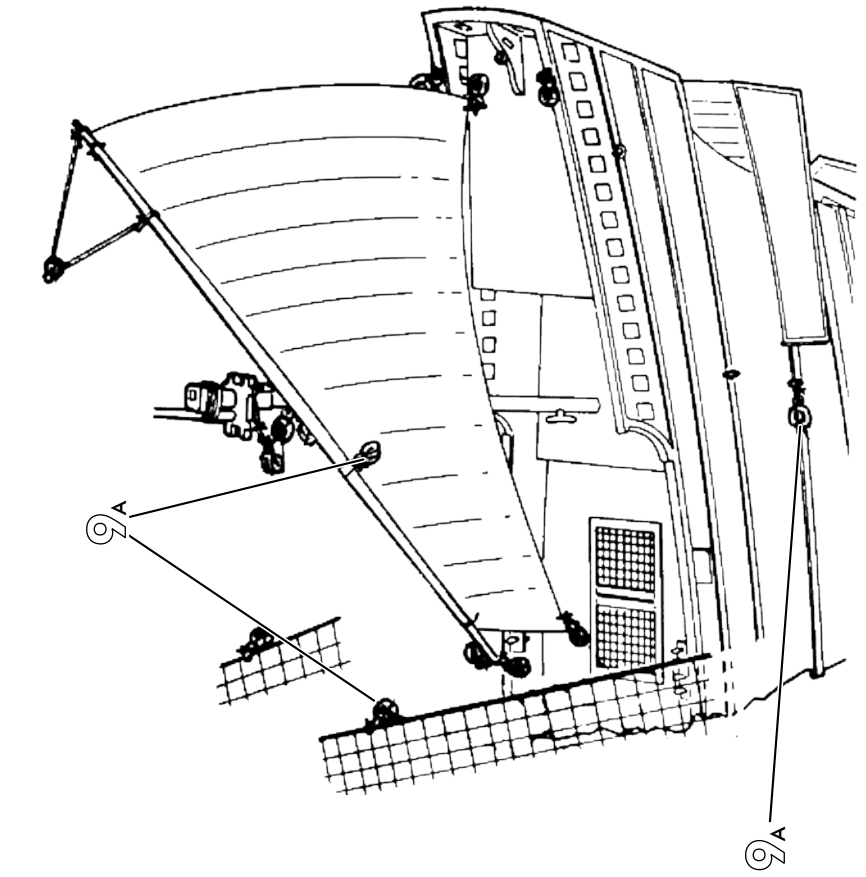
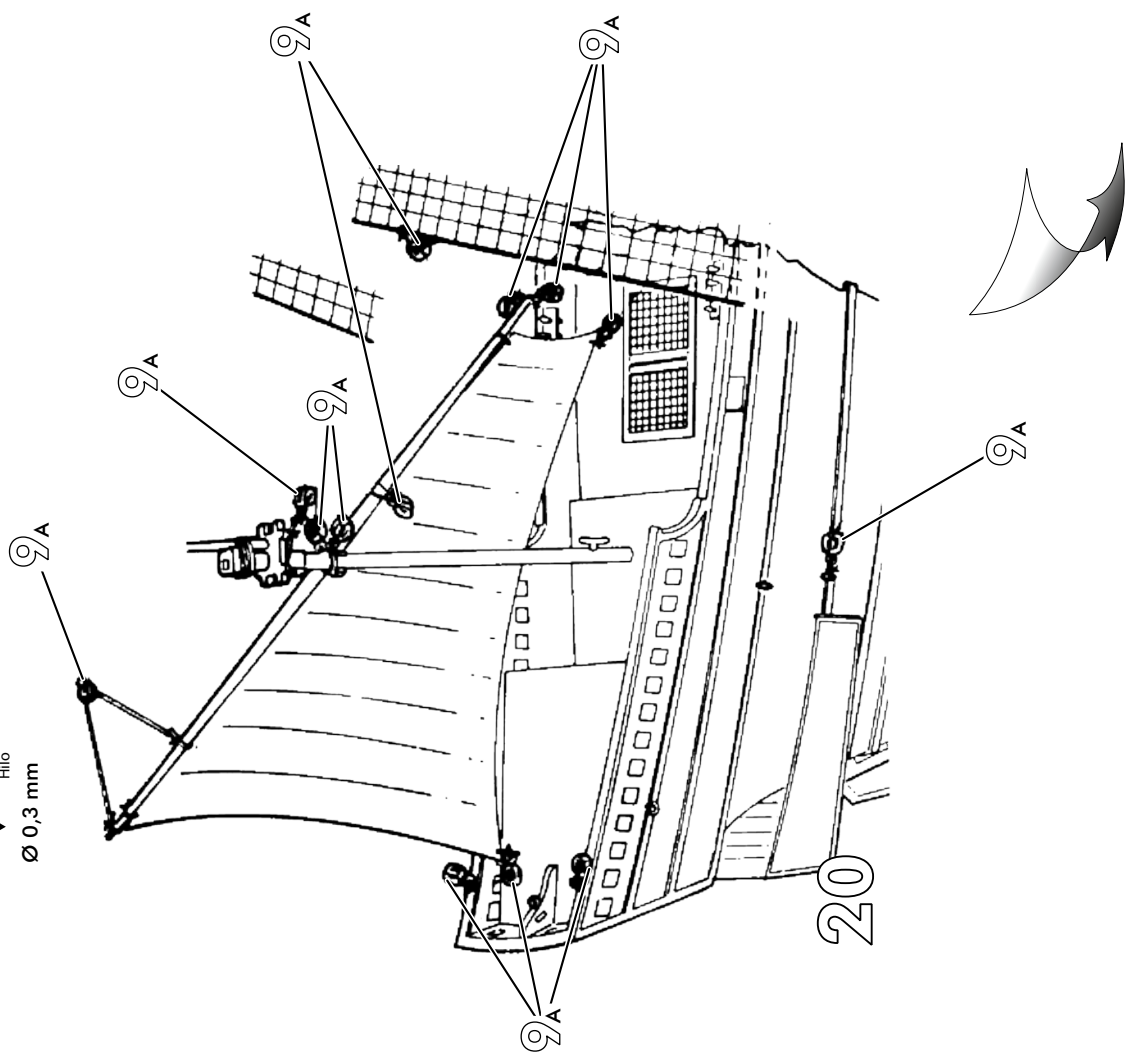

Fill
Thread
Garn
Hilo
Ø 0,3 mm





Ø 0,3 mm

- C₃₁ Ø 0,3 mm 150 mm **x2**
- C₃₂ Ø 0,3 mm 180 mm **x2**
- C₃₃ Ø 0,3 mm 120 mm
- C₃₄ Ø 0,3 mm 190 mm
- C₃₅ Ø 0,3 mm 140 mm

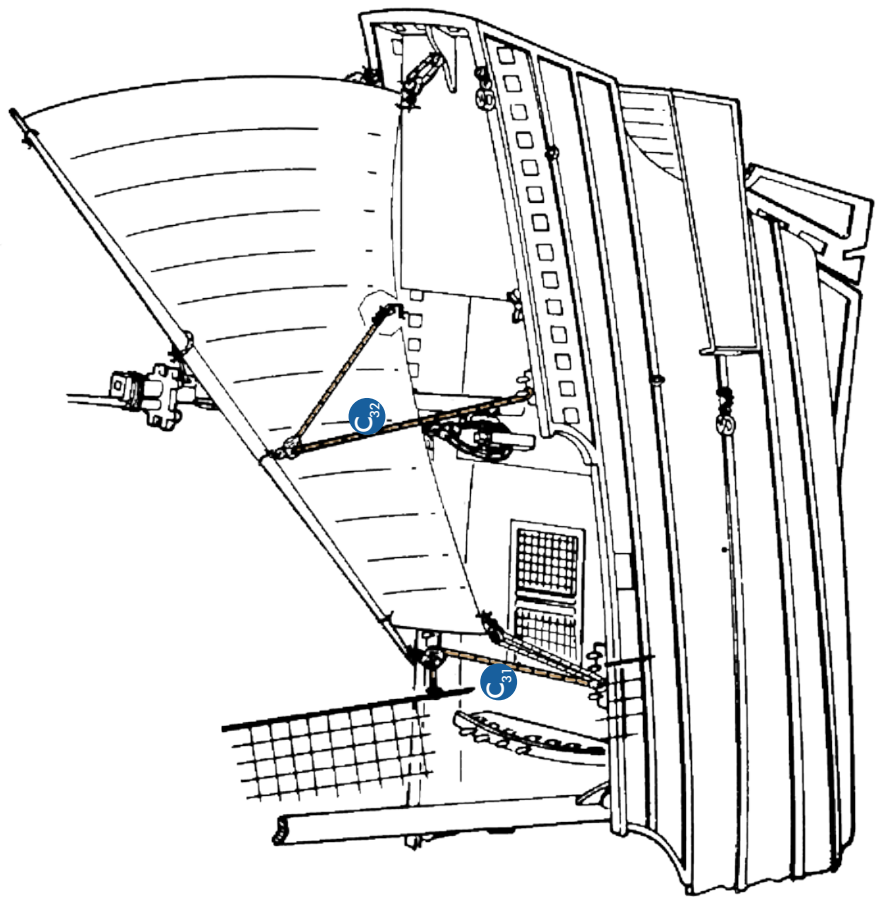
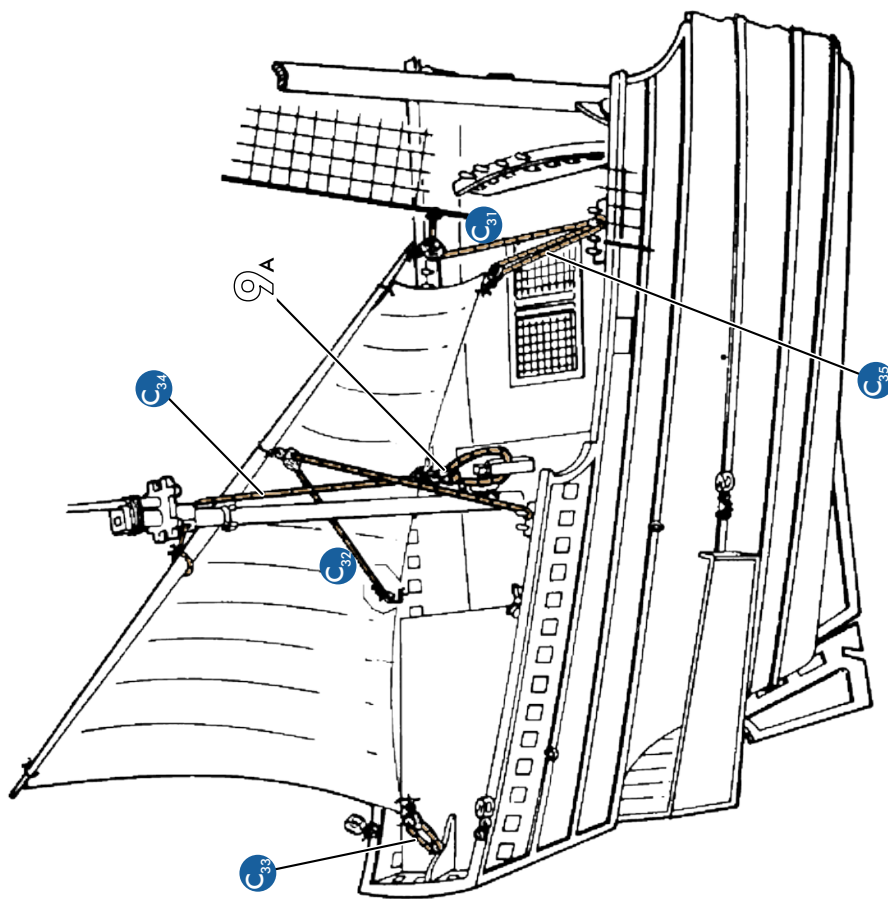

28

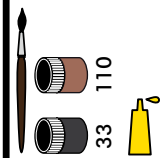

Fill
 Thread
 Gain
 Hilo
 Ø 0,3 mm

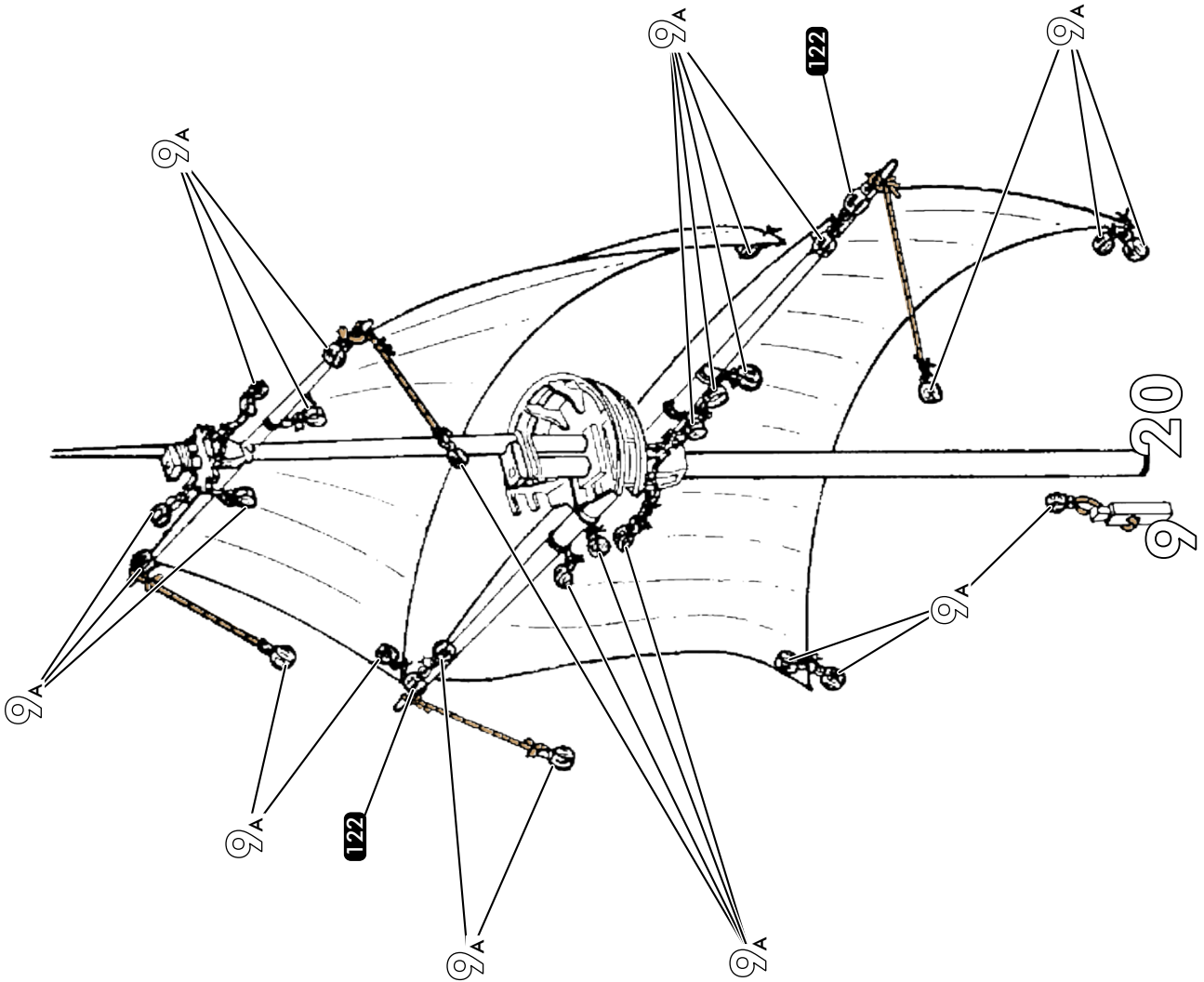
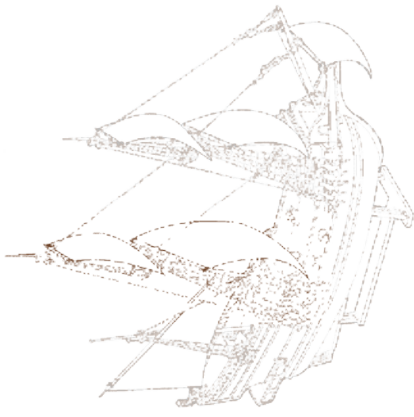

x2



Fill
Thread
Garn
Hilo

Ø 0,3 mm

- C₃₆ Ø 0,3 mm x2
- C₃₇ Ø 0,3 mm x2
- C₃₈ Ø 0,3 mm x2
- C₃₉ Ø 0,3 mm x2
- C₄₀ Ø 0,3 mm
- C₄₁ Ø 0,3 mm x2
- C₄₂ Ø 0,3 mm x2

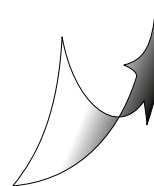
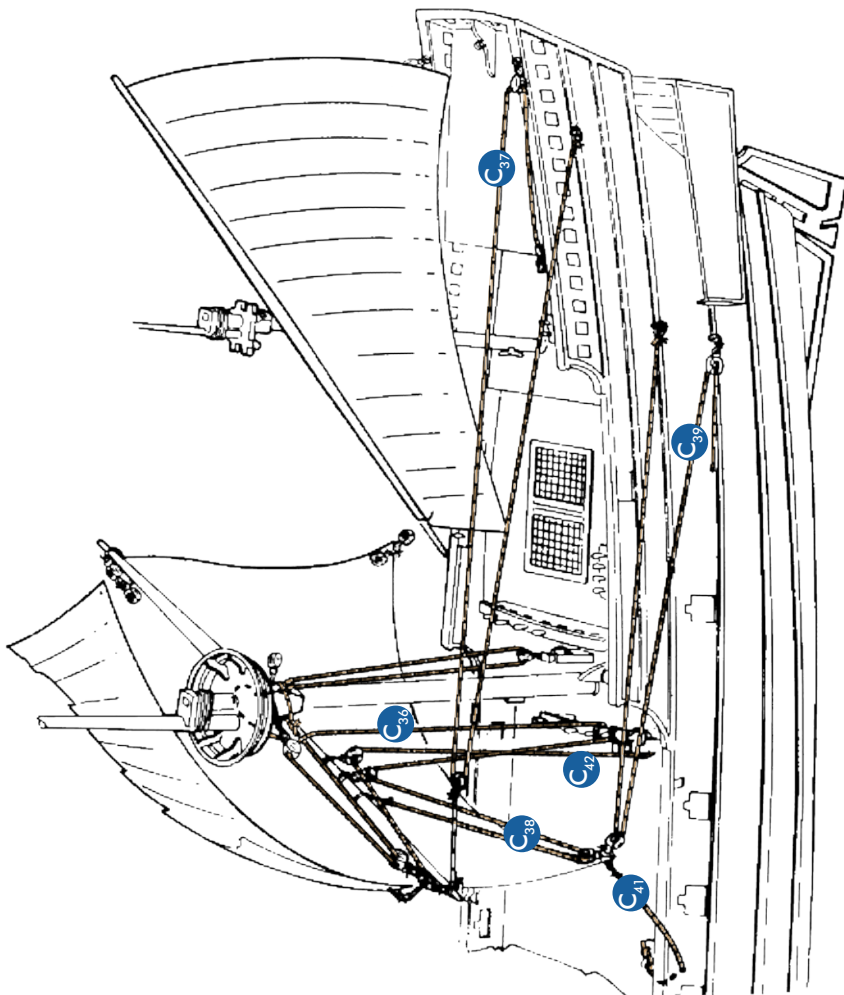
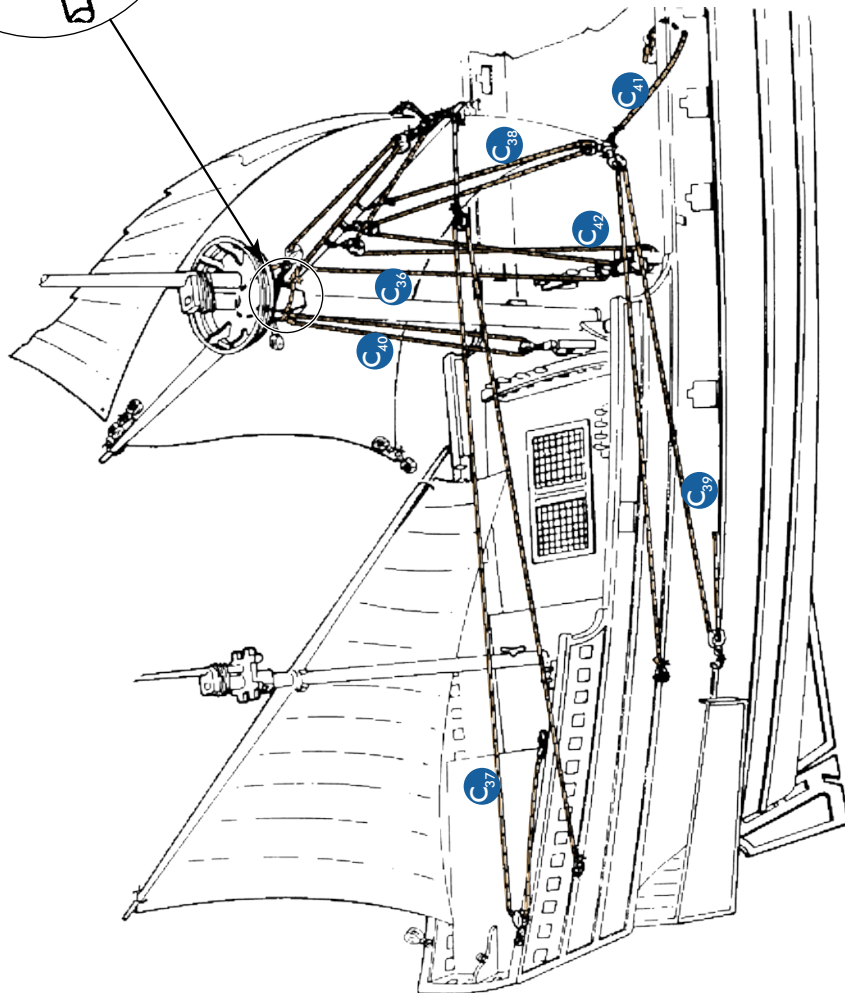
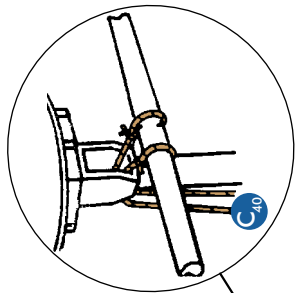

30



Ø 0,3 mm

- C₄₃ Ø 0,3 mm 340 mm
- C₄₄ Ø 0,3 mm 300 mm **x2**
- C₄₅ Ø 0,3 mm 390 mm **x2**
- C₄₆ Ø 0,3 mm 430 mm **x2**
- C₄₇ Ø 0,3 mm 200 mm **x2**

