

# Heller

# ALPINE A110 1600 S

80745



# DÉCOUVREZ LE MONDE DES PEINTURES ACRYLIQUES HELLER !

DISCOVER THE WORLD OF HELLER ACRYLIC PAINTS!  
ENTDECKEN SIE DIE WELT DER HELLER ACRYL-FARBEN!

**NEW**



- FACILE À UTILISER
- DILUABLE À L'EAU
- POTS DE PEINTURE STABLES
- BOUCHON À VIS SÉCURISÉ

- EASY TO USE
- DILUTABLE WITH WATER
- STABLE PAINT CANS
- SECURE SCREW CAP

- EINFACHE ANWENDUNG
- MIT WASSER VERDÜNNBAR
- STANDFESTE FARBDOSEN
- SICHERER SCHRAUBVERSCHLUSS

## Français

La saga Alpine A 110 débute à Dieppe en 1962. Créateur de la marque, Jean Rédélé va développer ce nouveau modèle sur la base du modèle A108 lui-même conçu à partir de la Renault Dauphine. L'A 110 empruntera de nombreuses pièces détachées à la toute nouvelle Renault 8. Les principales caractéristiques de cette voiture sont l'utilisation d'un châssis poutre et d'une coque verre/polyester fabriquée à l'origine dans les ateliers de Chappe et Gessalin. Le positionnement du moteur 4 cylindres Cléon fonte à 5 paliers en porte à faux arrière permet un très bon équilibre des masses. Equipé de 2 carburateurs double corps Weber, le modèle 1600 S développe 125 CH DIN et atteint la vitesse de 205 km/h. Très vite l'A110 va s'imposer comme la voiture de rallye de référence. Dès 1971 elle devient le modèle le plus performant en engrangeant de nombreux titres prestigieux dont le célèbre Rallye de Monte Carlo. L'A110 1600 S sera équipée du moteur de la Renault 16 TS. En 1973 Renault rachète Alpine et décide de participer au tout nouveau championnat du monde des Rallyes. Les 4 mousquetaires d'Alpine Renault (Jean-Claude Andruet, Jean-Pierre Nicolas, Jean-Luc Thérier, Bernard Darniche) gagneront 6 courses parmi les 13 inscrites au championnat du monde, faisant d'Alpine Renault le premier constructeur champion du monde des rallyes. 7176 exemplaires des différents modèles A110 seront produits à Dieppe entre 1963 et Juillet 1977. L'Espagne, le Brésil, le Mexique, la Bulgarie produiront sous licence les modèles Alpine. A ce jour l'Alpine A110 dite Berlinette reste le modèle le plus mythique des automobiles françaises sportives de ces 50 dernières années. En 2018 Renault fait revivre la fabuleuse épopée Alpine avec son tout nouveau modèle qui fascine déjà tous les amoureux de la marque.

## English

The story of the Alpine A110 began in Dieppe, France, in 1962. The brand's creator, Jean Rédélé, developed this new model based on the A108, which itself was designed around the Renault Dauphine. The A110 borrowed many spare parts from the all-new Renault 8. The main features of this new car were the use of a beam frame and a glass/polyester shell originally made in Chappe et Gessalin workshops. The position of the 4-cylinder cast iron Cléon engine with 5 bearings in the rear overhang allows the weight to be balanced effectively. Equipped with two Weber twin barrel carburetors, the 1600 S model managed 125 DIN HP and achieved speeds of 205 km/h. The A110 quickly established itself as the benchmark for rally cars. From 1971 it became the most successful model, garnering numerous prestigious trophies including the famous Monte Carlo Rally. The A110 1600 S went on to be fitted with the Renault 16 TS engine. In 1973, Renault acquired Alpine and decided to take part in the brand new World Rally Championship. The four musketeers of Alpine Renault (Jean-Claude Andruet, Jean-Pierre Nicolas, Jean-Luc Thérier and Bernard Darniche) won 6 of the 13 courses in the championship, making the company the world's champion carmaker. 7,176 cars across the various A110 models were made in Dieppe between 1963 and 1977. Spain, Brazil, Mexico and Bulgaria also manufactured Alpine models under licence. Even today, the Alpine A110 or Berlinette remains a legend of French sportscars. In 2018 Renault revived the Alpine saga with its brand new model, which is already starting to captivate the brand's aficionados.

### Modèle 1600 S Groupe IV

<b>Carrosserie</b>	• Polyester/glass fibre • Steel chassis (tube and sheet)
<b>Poids à vide</b>	685 kg
<b>Longueur</b>	3850 mm
<b>Largeur</b>	1520 mm
<b>Hauteur</b>	Hauteur
<b>Empattement</b>	2100 mm
<b>Voie AV</b>	1358 mm
<b>Voie AR</b>	1357 mm
<b>Motorisation</b>	
<b>Moteur et transmission</b>	AR
<b>Moteur</b>	4 cylindres en ligne / 8 soupapes
<b>Cylindrée</b>	1565/1608 cm <sup>3</sup>
<b>Carburateurs</b>	x 2 WEBER 45 DCOE double-corps horizontaux
<b>Puissance</b>	165 CV à 7000 tr/mn
<b>Couple maximum</b>	19,50 MKG à 5000 tr/mn
<b>Vitesse maximum</b>	225 km/h suivant les rapports utilisés
<b>Boite de vitesses</b>	type 364, 5 rapports
<b>Roues, suspension et freinage</b>	
4 roues indépendantes, jantes en alliage léger Ressort hélicoïdaux et barre antiroulis à l'avant 2 amortisseurs hydrauliques télescopiques à l'avant et 4 à l'arrière 4 Freins à disques 254 mm, double circuit de freinage	
<b>Pneus AV</b>	145x15
<b>Pneus AR</b>	165x13

### 1600 S Group IV model

<b>Bodywork</b>	• Polyester/glass fibre • Steel chassis (tube and sheet)
<b>Empty weight</b>	685 kg
<b>Length</b>	3850 mm
<b>Width</b>	1520 mm
<b>Height</b>	1130 mm
<b>Wheelbase</b>	2100 mm
<b>Front track</b>	1358 mm
<b>Rear track</b>	1357 mm
<b>Engine</b>	
<b>Engine and rear transmission</b>	4 in-line cylinders / 8-valve
<b>Capacity</b>	1565/1608 cm <sup>3</sup>
<b>Carburetors</b>	2x Weber 45 DCOE twin horizontal barrel
<b>Power</b>	165 bhp at 7000 rpm
<b>Max torque</b>	19.50 mkg at 5000 rpm
<b>Max speed</b>	225 km/h depending on the ratio used
<b>Transmission</b>	364 type, 5 ratios
<b>Wheels, suspension and braking</b>	
4 independent wheels, light alloy rims Coil springs and stabiliser bar at the front 2 hydraulic telescopic shock absorbers at the front and 4 at the rear 4x 254 mm disc brakes, dual-circuit braking	
<b>Front tyres</b>	145x15
<b>Rear tyres</b>	165x13



## Deutsch

Die Sage des Alpine A 110 begann 1962 in Dieppe. Jean Rédélé, der Schöpfer der Marke, entwickelte dieses neue Modell auf der Grundlage des A108-Modells, das vom Renault Dauphine stammte. Viele Teile des A 110 stammten aus dem damals neuen Renault 8. Die Besonderheiten dieses Wagens waren die Verwendung eines Trägerrahmenfahrgestells und einer Glas/ Polyester-Karosserie, die ursprünglich in den Werkstätten Chappe und Gessalin hergestellt wurde. Die Lage des 4-Zylinder-Gussmotors im Hecküberhang ermöglichte eine sehr gute Massenverteilung. Ausgestattet mit 2 Weber-Doppelvergasern entwickelte das Modell 1600 S 125 DIN PS und erreichte eine Geschwindigkeit von 205 km/h. Sehr schnell wurde der A110 zum Maßstab bei Rallyeautos. Im Jahr 1971 wurde es das erfolgreichste Modell und gewann viele prestigeträchtige Titel, darunter die berühmte Rallye Monte Carlo. Der A110 1600 S wurde mit dem Motor des Renault 16 TS ausgerüstet. 1973 kaufte Renault Alpine und entschied sich für die Teilnahme an der brandneuen Rallye-Weltmeisterschaft. Die 4 Musketiere von Alpine Renault (Jean-Claude Andruet, Jean- Pierre Nicolas, Jean-Luc Thérier, Bernard Darniche) gewannen 6 von 13 Rennen der Weltmeisterschaft und machten Alpine Renault zum ersten Hersteller-Weltmeister bei Rallyes. Zwischen 1963 und Juli 1977 wurden in Dieppe 7176 Exemplare der verschiedenen A110-Modelle hergestellt. Spanien, Brasilien, Mexiko und Bulgarien produzierten die Alpine-Modelle unter Lizenz. Bis heute ist der Alpine A110 namens Berlinette das Kultmodell der französischen Sportwagen der letzten 50 Jahre. Im Jahr 2018 ließ Renault den fabelhaften Alpine mit seinem brandneuen Modell, das bereits alle Liebhaber der Marke fasziniert, wieder aufleben.

## Español

La saga Alpine A 110 comenzó en Dieppe en 1962. Jean Rédélé, creador de la marca, desarrollaría este nuevo modelo a partir del propio modelo A108 diseñado a partir del Renault Dauphine. El A 110 tomaría prestadas muchas piezas de repuesto del nuevo Renault 8. Las características principales de este coche son el uso de un chasis de viga y una caja de carrocería de vidrio/ poliéster originalmente fabricada en los talleres de Chappe et Gessalin. El posicionamiento del motor Cléon de fundición de 4 cilindros con 5 cojinetes en el voladizo trasero permite un muy buen equilibrio de las masas. Equipado con 2 carburadores de doble cuerpo Weber, el modelo 1600 S desarrolla 125 CV DIN y alcanza una velocidad de 205 km/h. El A110 no tardará en convertirse en el coche de rally de referencia. En 1971 se convirtió en el modelo más exitoso y obtuvo muchos títulos prestigiosos, incluyendo el famoso Rally de Monte Carlo. El A110 1600 S se equiparía con el motor del Renault 16 TS. En 1973, Renault compra Alpine y decide participar en cualquier nuevo campeonato del mundo de los rallies. Los 4 mosqueteros de Alpine Renault (Jean-Claude Andruet, Jean-Pierre Nicolas, Jean-Luc Thérier, Bernard Darniche) ganarían 6 carreras entre las 13 inscritas en el campeonato del mundo, convirtiéndose a Alpine Renault en el primer constructor campeón del mundo de los rallies. Entre 1963 y julio de 1977 se produjeron en Dieppe 7176 ejemplares de los diferentes modelos A110. España, Brasil, México y Bulgaria producirían bajo licencia los modelos Alpine. Hasta el día de hoy, el Alpine A110 llamado Berlinette sigue siendo el modelo más mítico de los coches deportivos franceses de los últimos 50 años. En 2018 Renault insufla nueva vida a la fabulosa epopeya del Alpine con su nuevo modelo, que ya fascina a todos los amantes de la marca.

### Modell 1600 S Gruppe IV

<b>Karosserie</b>	• Polyester/Glasfaser • Stahlrahmen (Rohr und Blech)
<b>Leergewicht</b>	685 kg
<b>Länge</b>	3850 mm
<b>Breite</b>	1520 mm
<b>Höhe</b>	1130 mm
<b>Achsabstand</b>	2100 mm
<b>Spur vorne</b>	1358 mm
<b>Spur hinten</b>	1357 mm
<b>Motorisierung</b>	
<b>Motor und Getriebe hinten</b>	4 Zylinder in Reihe / 8 Ventile
<b>Hubraum</b>	1565/1608 cm <sup>3</sup>
<b>Vergaser</b>	horizontaler Doppelvergaser WEBER 45 DCOE
<b>Leistung</b>	165 PS bei 7000 U/min
<b>Maximales Drehmoment</b>	19,50 MKG bei 5000 min <sup>-1</sup>
<b>Maximale Geschwindigkeit</b>	225 km/h je nach verwendetem Gang
<b>Getriebe</b>	Typ 364, 5 Gänge
<b>Räder, Federung und Bremsen</b>	
4 unabhängige Räder, Leichtmetallräder Spiralfeder und Stabilisator vorne 2 hydraulische Teleskopstoßdämpfer vorne und 4 hinten 4 Scheibenbremsen 254 mm, doppelter Bremskreis	
<b>Reifen vorne</b>	145x15
<b>Reifen hinten</b>	165x13

### Modelo 1600 S Grupo IV

<b>Carrocería</b>	• poliéster / fibra de vidrio • Chasis de acero (tubo y chapa)
<b>Peso en vacío</b>	685 kg
<b>Longitud</b>	3850 mm
<b>Anchura</b>	1520 mm
<b>Altura</b>	1130 mm
<b>Batalla</b>	2100 mm
<b>Vía delantera</b>	1358 mm
<b>Vía trasera</b>	1357 mm
<b>Planta motriz</b>	
<b>motor y transmisión traseros</b>	4 cilindros en línea / 8 válvulas
<b>Cilindrada</b>	1565/1608 cm <sup>3</sup>
<b>Carburadores</b>	2 WEBER 45 DCOE horizontales de doble cuerpo
<b>Potencia</b>	165 CV a 7000 rpm
<b>Par máximo</b>	19,50 mkg a 5000 rpm
<b>Velocidad máxima</b>	225 km/h dependiendo de la marcha utilizada
<b>Caja de cambios</b>	tipo 364, 5 marchas
<b>Ruedas, suspensión y frenado</b>	
4 ruedas independientes, llantas de aleación ligera Muelle helicoidal y barra estabilizadora en la parte delantera 2 amortiguadores hidráulicos telescópicos en la parte delantera y 4 en la trasera 4 frenos de disco de 254 mm, doble circuito de frenado	
<b>Neumáticos delanteros</b>	145x15
<b>Neumáticos traseros</b>	165x13

## Italiano

La saga Alpine A 110 ebbe inizio a Dieppe nel 1962. Il fondatore del marchio Jean Rédélé sviluppò questo nuovo modello sulla base del modello A108 da lui progettato ispirandosi alla Renault Dauphine. L'A 110 presterà diverse parti alla nuova Renault 8. Le caratteristiche principali di questa vettura erano l'impiego di uno chassis a trave e una scocca in vetro/poliestere originariamente prodotta nei laboratori di Chappe e Gessalin. Il posizionamento del motore 4 cilindri Cléon in ghisa a 5 cuscinetti in oggetto posteriore permetteva un ottimo equilibrio delle masse. Dotato di 2 carburatori a corpo doppio Weber, il modello 1600 S era in grado di sviluppare 125 CV DIN e raggiungere 205 km/h di velocità. Velocissima, l'A110 si impose come riferimento delle auto da rally. A partire dal 1971 diventò il modello più potente della gamma, vincendo numerose competizioni prestigiose fra cui il celebre Rally di Montecarlo. L'A110 1600 S 16 TS fu dotata del motore della Renault 16 TS. Nel 1973 Renault acquisì il marchio Alpine e decise di partecipare al nuovo campionato del mondo di rally: i "quattro moschettieri" di Alpine Renault (Jean-Claude Andruet, Jean-Pierre Nicolas, Jean-Luc Thérier, Bernard Darniche) vinsero 6 gare fra le 13 del campionato del mondo, rendendo Alpine Renault il primo costruttore campione del mondo di rally. 7176 esemplari di diversi modelli di A110 furono prodotti a Dieppe fra il 1963 e il luglio 1977. Anche Spagna, Brasile, Messico e Bulgaria produssero su licenza i modelli Alpine. Ad oggi, l'Alpine A110 "Berlinette" resta il modello più iconico fra le auto francesi sportive degli ultimi 50 anni. Nel 2018 Renault fa rivivere la straordinaria epopea Alpine con il nuovo modello della gamma, conquistando tutti gli affezionati del marchio.

## Nederlands

Het verhaal van de Alpine A 110 startte in 1962 te Dieppe, Frankrijk. De maker van het merk, Jean Rédélé ontwikkelde dit nieuw model op basis van het model A180, dat op zijn beurt op basis van de Renault Dauphine was ontworpen. De A 110 ontleende vele reserveonderdelen van de volledig nieuwe Renault 8. De belangrijkste eigenschappen van dit voertuig waren het gebruik van een centraal buischassis en een romp van glas/polyester, gemaakt in de werkplaatsen van Chappe et Gessalin. De positie van de gietijzeren Cléon motor met 4 cilinders en 5 lagers in de achteroverhang zorgde voor een zeer goed evenwicht van de massa. Het model 1600 S met 2 Weber carburatoren met dubbele behuizing ontwikkelde 125 DIN PK en bereikte een snelheid van 205 km/u. De zeer snelle A 110 drong zich op als de rallywagen van zijn tijd. Vanaf 1971 was dit model het meest succesvol en haalde het verschillende prestigieuze titels binnen waaronder de vermaarde Rally van Monte Carlo. De A110 1600 S werd uitgerust met de motor van de Renault 16 TS. In 1973 kocht Renault Alpine terug en besloot het om deel te nemen aan het volledig nieuwe Wereldkampioenschap Rally. De 4 musketiers van Alpine Renault (Jean-Claude Andruet, Jean-Pierre Nicolas, Jean-Luc Thérier en Bernard Darniche) wonnen 6 van de 13 wedstrijden van het wereldkampioenschap, wat Alpine Renault de eerste constructeur van het Wereldkampioenschap Rally maakte. Tussen 1963 en juli 1977 werden er 7176 exemplaren van verschillende modellen te Dieppe gebouwd. Spanje, Brazilië, Mexico en Bulgarije bouwden tevens Alpine-modellen onder licentie. Tot op de dag van vandaag blijft de Alpine A110, ook wel bekend als de "Berlinette", de meest mythische Franse sportauto van de laatste 50 jaar. In 2018 heeft Renault de epische Alpine nieuw leven ingeblazen met het aanbieden van een volledig nieuw model die de harten van alle liefhebbers van het merk reeds doen smelten.

### Modello 1600 S Gruppo IV

<b>Carrozzeria</b>	• Poliestere/fibra di vetro	• Poliestere/fibra di vetro Chassis in acciaio (tubo in tolla)
<b>Peso a vuoto</b>	685 kg	
<b>Lunghezza</b>	3.850 mm	
<b>Larghezza</b>	1.520 mm	
<b>Altezza</b>	1.130 mm	
<b>Passo</b>	2.100 mm	
<b>Corsa anteriore</b>	1.358 mm	
<b>Corsa posteriore</b>	1.357 mm	
<b>Motori</b>		
<b>Motore e trasmissione AR</b>	4 cilindri in linea/8 valvole	
<b>Cilindrata</b>	1.565/1.608 cm <sup>3</sup>	
<b>Carburatori</b>	x 2 WEBER 45 DCOE a corpo doppio orizzontali	
<b>Potenza</b>	165 CV a 7000 g/mn	
<b>Coppia massima</b>	19,50 MKG a 5000 g/mn	
<b>Velocità massima</b>	225 km/h a seconda dei rapporti	
<b>Cambio</b>	tipo 364, 5 rapporti	
<b>Ruote, sospensioni e freni</b>	4 ruote indipendenti, cerchi in lega leggera Molle elicoidali e barre antirollio anteriori 2 ammortizzatori idraulici telescopici anteriori e 4 posteriori 4 freni a disco 254 mm, doppio circuito di frenata	
<b>Pneumatici AV</b>	145x15	
<b>Pneumatici AR</b>	165x13	

### Model 1600 S Groep IV

<b>Carrosserie:</b>	• Polyester/glasveze	• Stalen chassis (buizen en plaatwerk)
<b>Tarra gewicht</b>	685 kg	
<b>Lengte</b>	3850 mm	
<b>Breedte</b>	1520 mm	
<b>Hoogte</b>	1130 mm	
<b>Wielbasis</b>	2100 mm	
<b>Spoorbreedte vooraan</b>	1358 mm	
<b>Spoorbreedte achteraan</b>	1357 mm	
<b>Motorisering</b>		
<b>Motor en achterwielaandrijving</b>	4 cilinders in lijn / 8 kleppen	
<b>Cilinderinhoud</b>	1565/1608 cm <sup>3</sup>	
<b>Carburatoren</b>	x 2 horizontale WEBER 45 DCOE met dubbele behuizing	
<b>Vermogen</b>	165 PK aan 7000 omw/min	
<b>Maximum koppel</b>	19,50 MKG aan 5000 omw/min	
<b>Maximum snelheid</b>	225 km/u volgens de gebruikte rapporten	
<b>Versnellingsbak</b>	type 364, 5 versnellingen	
<b>Wielen, vering en remsysteem</b>	4 onafhankelijke wielen, velgen van lichte legering Spiraalveren en stabilisatorstang aan de voorkant 2 hydraulische telescopische dempers aan de voorkant en 4 aan de achterkant 4 254mm schijfremmen, dubbel remcircuit	
<b>Voorbanden</b>	145x15	
<b>Achterbanden</b>	165x13	

PEINTURES ESSENTIELLES / ESSENTIAL PAINTS



11  
Argent  
Silver  
Silber



52  
Bleu métallique  
Metallic blue  
Metallic Blau



18  
Orange brillant  
Gloss orange  
Glänzend-Orange



85  
Noir satiné  
Satin black  
Seidenmatt-Schwarz



321  
Rouge transparent  
Clear red  
Durchsichtiges Rot



322  
Orange transparent  
Clear orange  
Durchsichtiges Orange

PEINTURES COMPLEMENTAIRES / ADDITIONAL PAINTS

Disponibles séparément chez votre revendeur de maquettes / Available separately at you local hobby shop.



2  
Vert émeraude brillant  
Gloss emerald green  
Glänzend-Smaragdgrün



14  
Bleu brillant  
Gloss blue  
Glänzend-Blau



19  
Rouge vif brillant  
Gloss bright red  
Glänzend-Hellrot



22  
Blanc brillant  
Gloss white  
Glänzend-Weiss



33  
Noir mat  
Matt black  
Matt-Schwarz



56  
Aluminium  
Aluminium  
Aluminium



69  
Jaune brillant  
Gloss yellow  
Glänzend-Gelb



92  
Gris fer mat  
Matt iron grey  
Matt-Eisengrau



130  
Blanc satiné  
Satin white  
Satin Weiss

- Si aucune teinte n'est spécifiée, peindre dans les couleurs de la version choisie. Se reporter aux pages 11 et 12 pour le détail du schéma de peinture.
- When no color is specified, paint the item with colors of chosen version. Refer to pages 11 - 12 for painting livery.
- Wenn keine Farbe angegeben ist, Teile mit den Farben der gewählten Version bemalen. Beachten Sie die Seiten 11 - 12 für die Lackierung und Markierung.
- Cuando ningún color es especificado, pintarle con los colores del tema de la versión elegida. Vea las páginas 11 - 12 para obtener detalles de pintura.



• N° 18 – 1ère - Jean-Claude ANDRUET / "Biche" (Michèle ESPINOSI-PETIT) - Rallye de Monte Carlo 1973

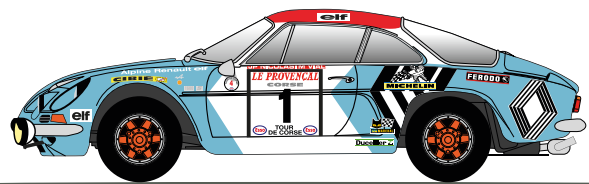

• N° 1 – 1ère - Jean-Pierre NICOLAS / Michel VIAL - Tour de Corse 1973

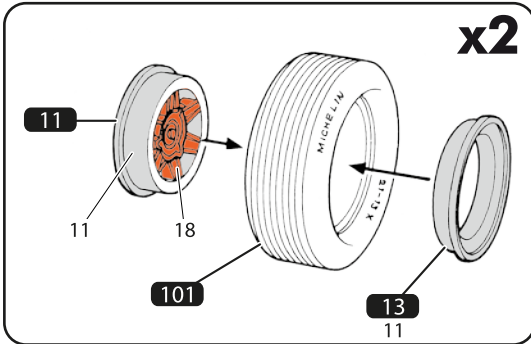
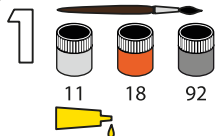

A → B

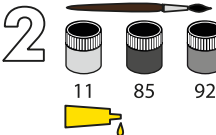
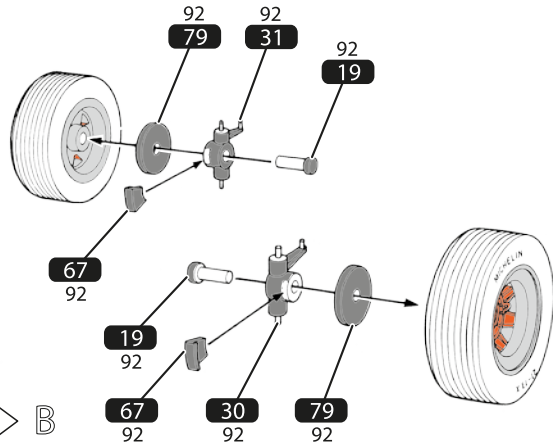

Encliqueter  
Snap fit  
Schnappsitz  
Engastar

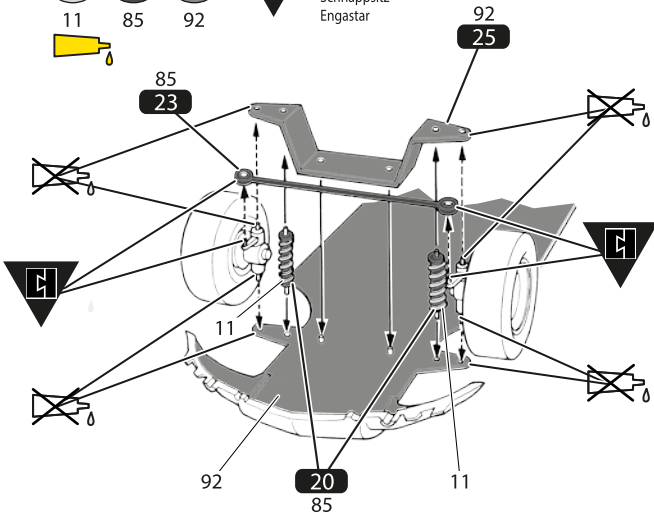

A → B

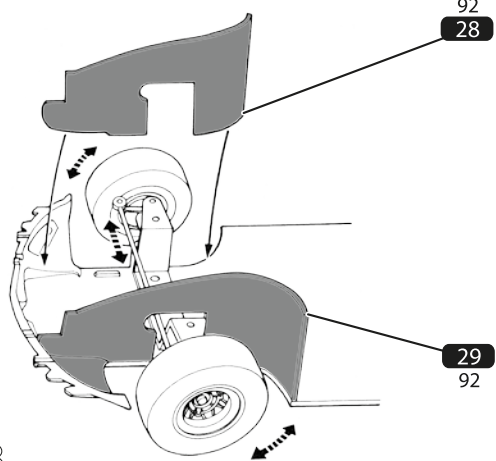

3

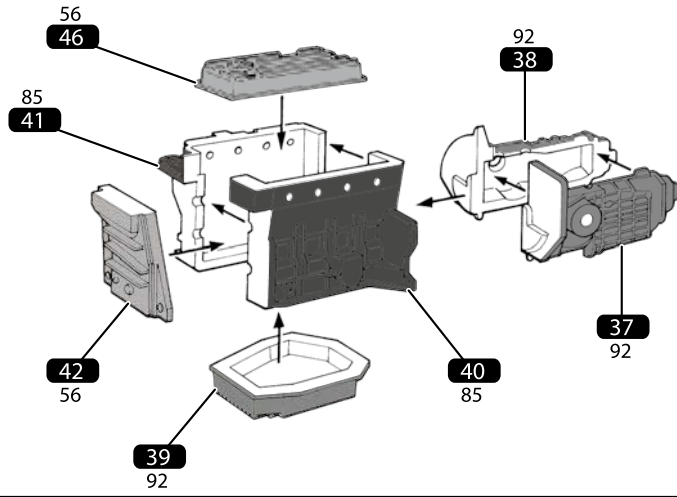
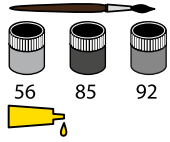

4

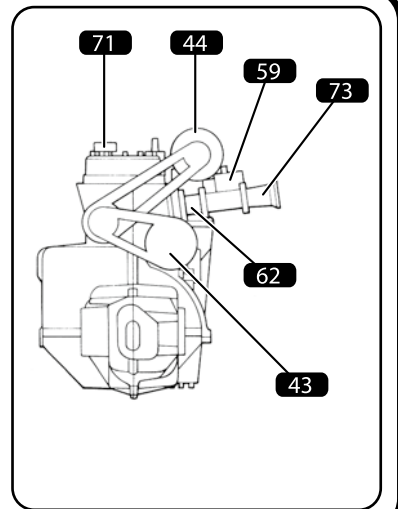
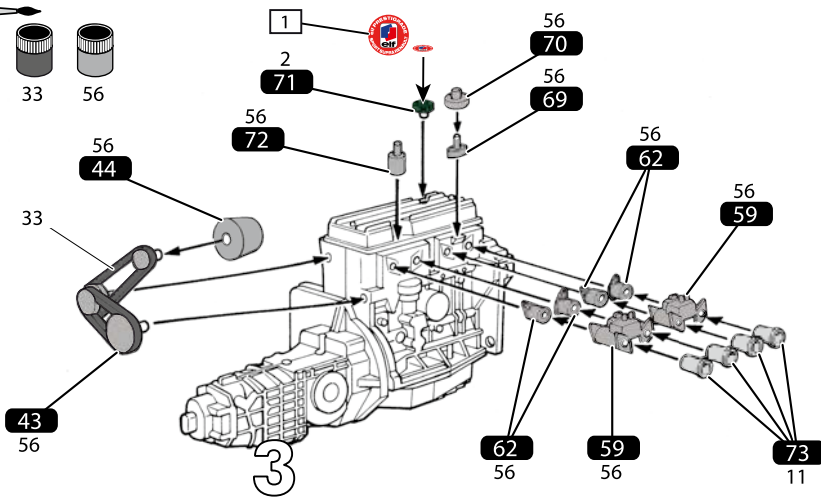
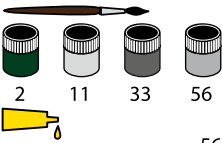

5

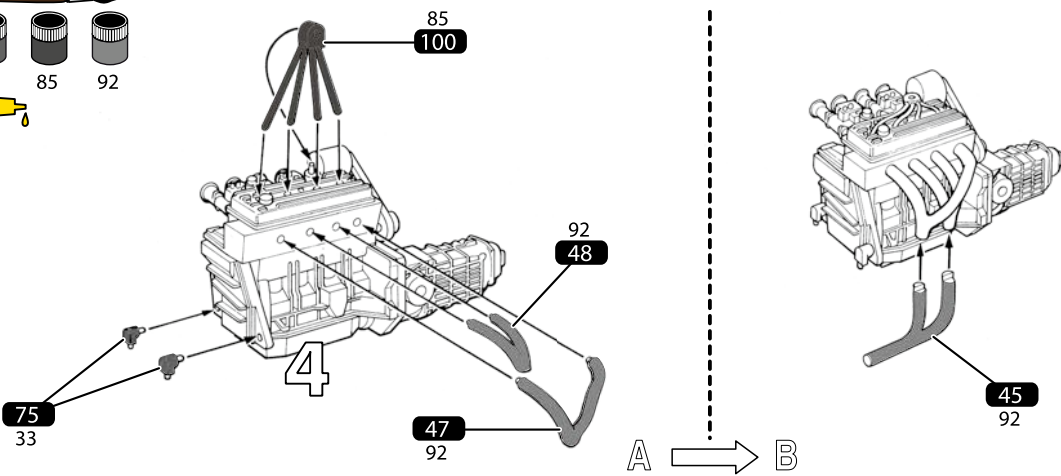
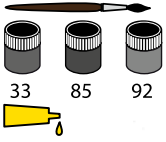

6

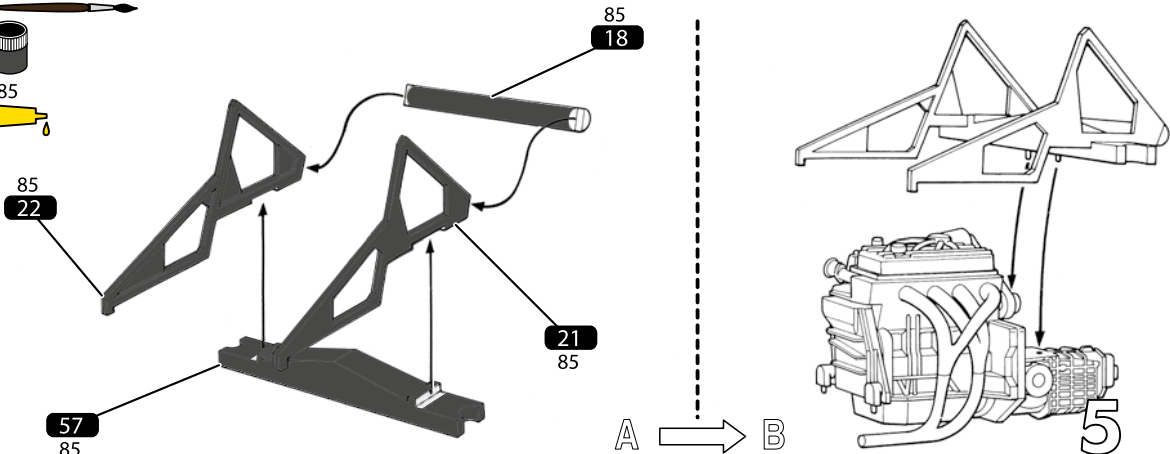
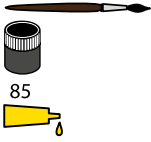

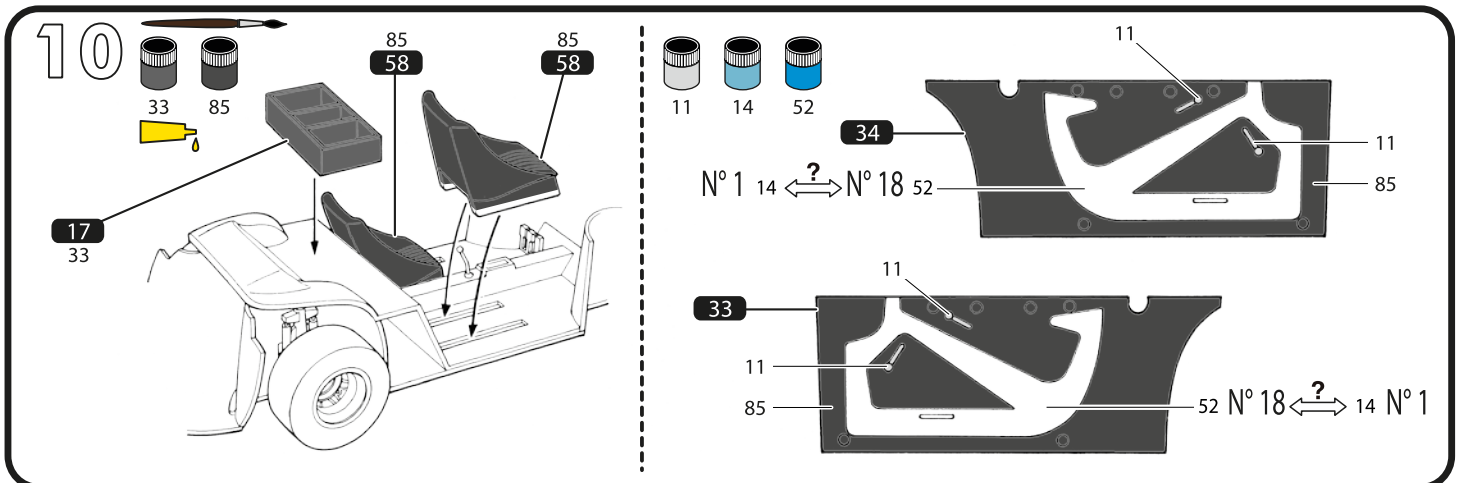
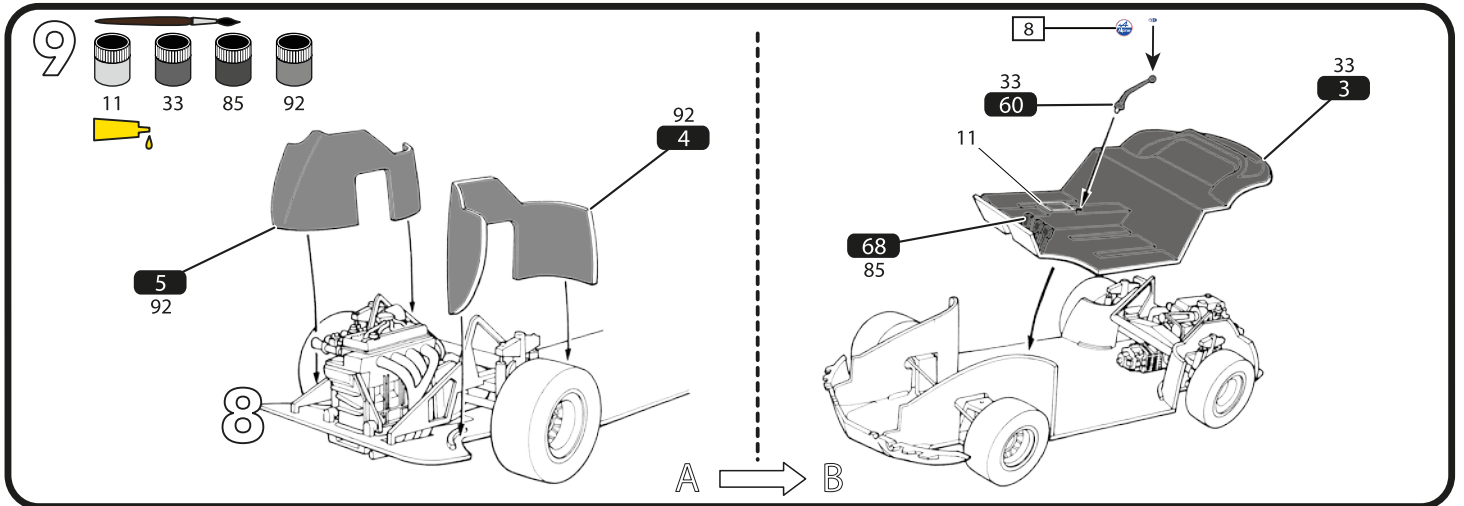
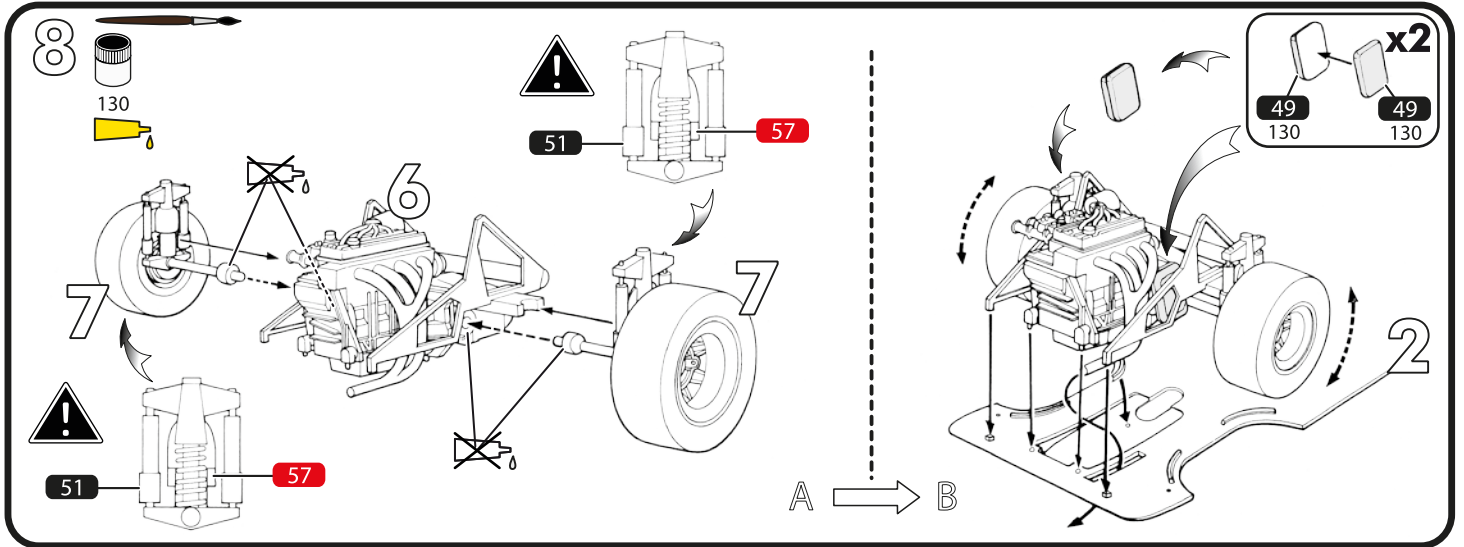
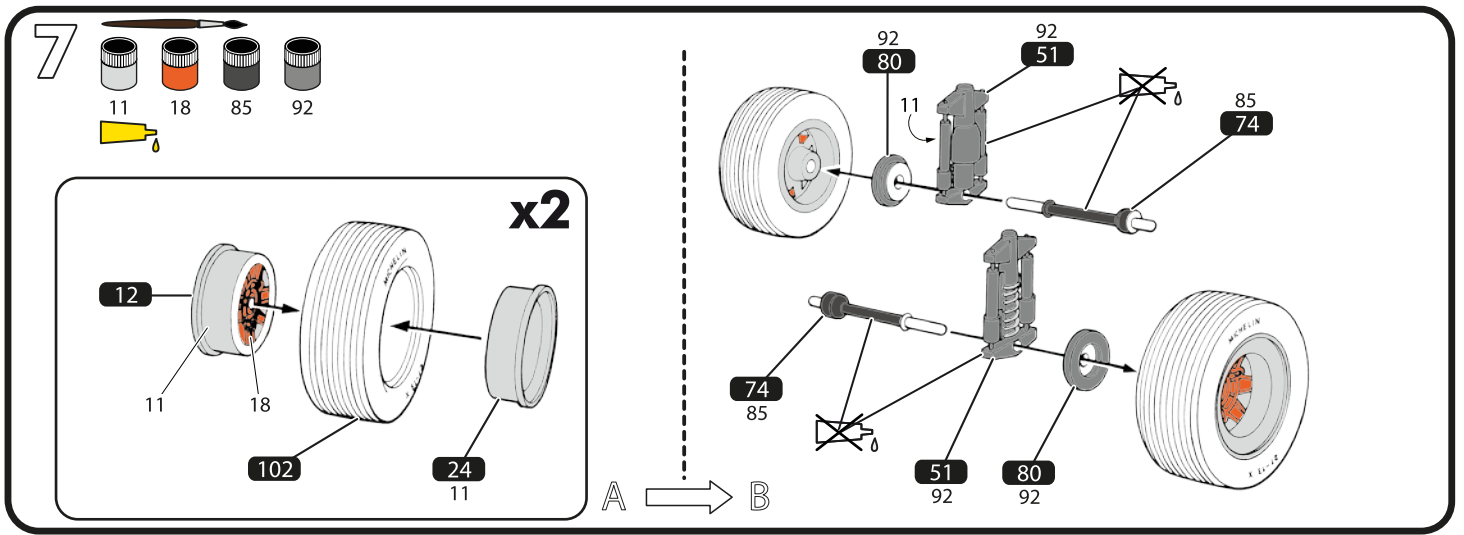



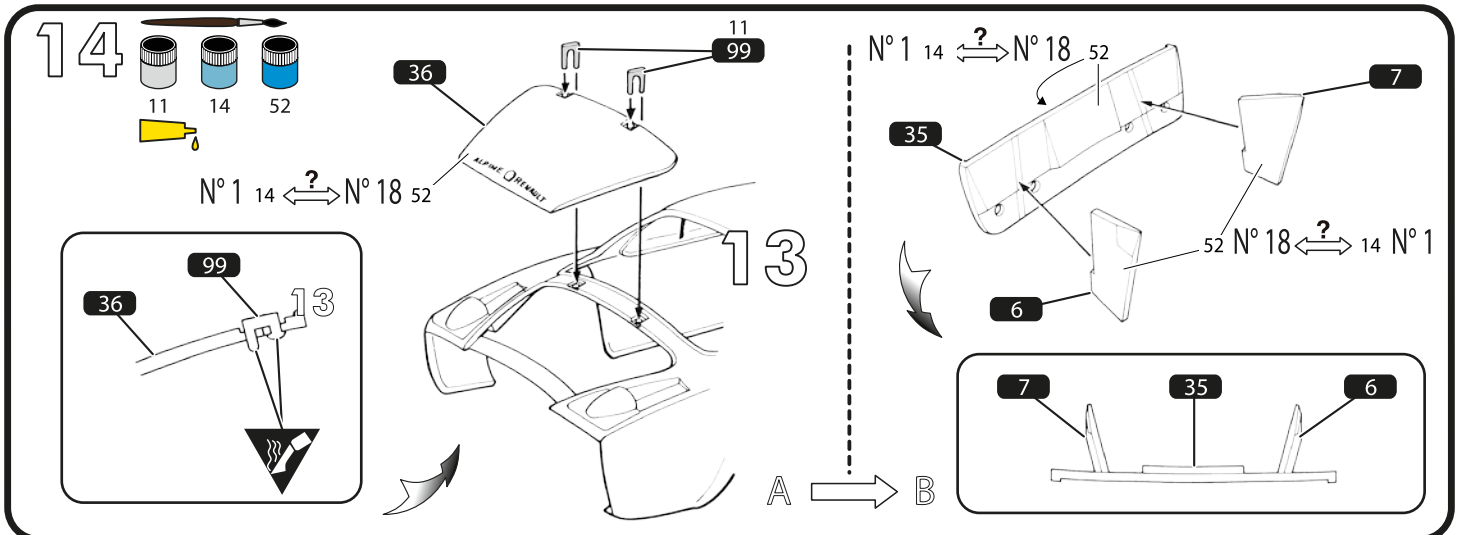
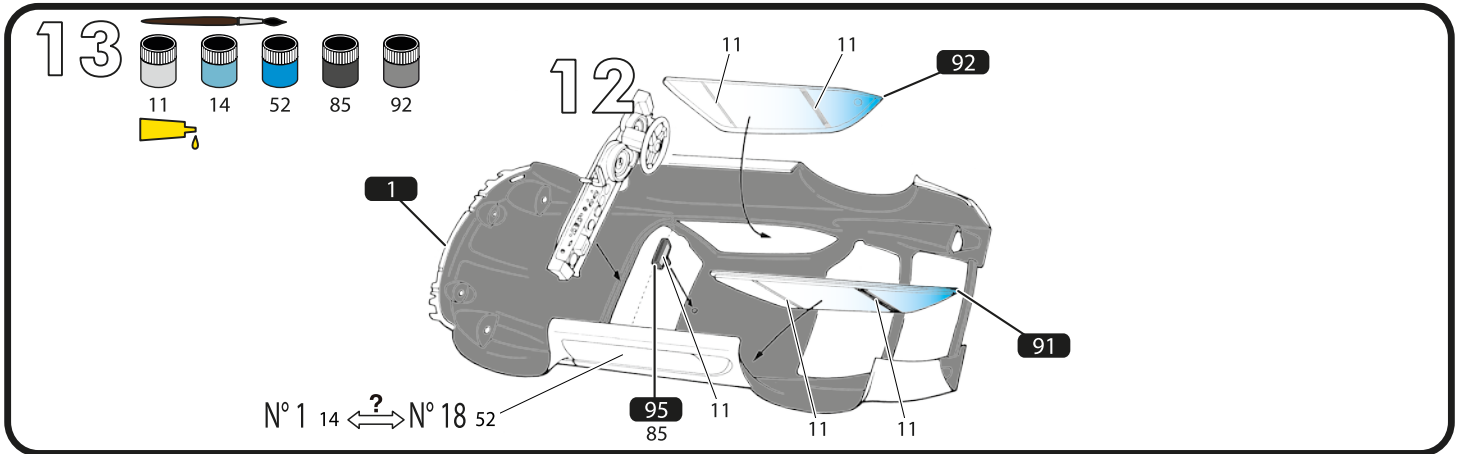
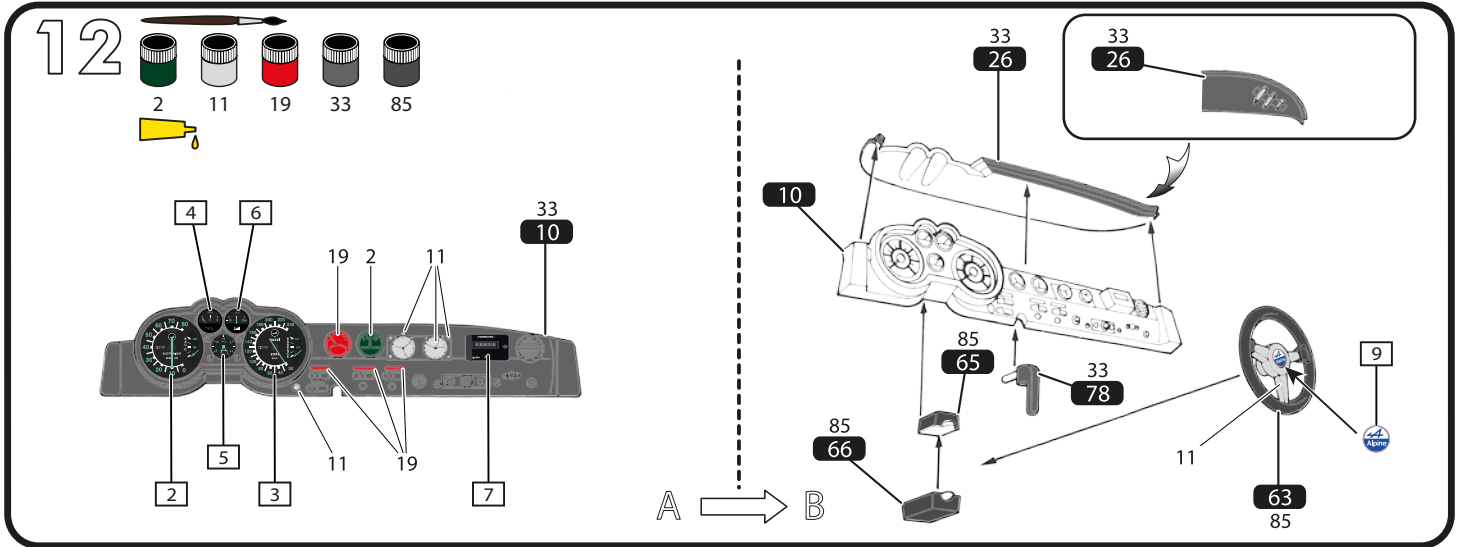
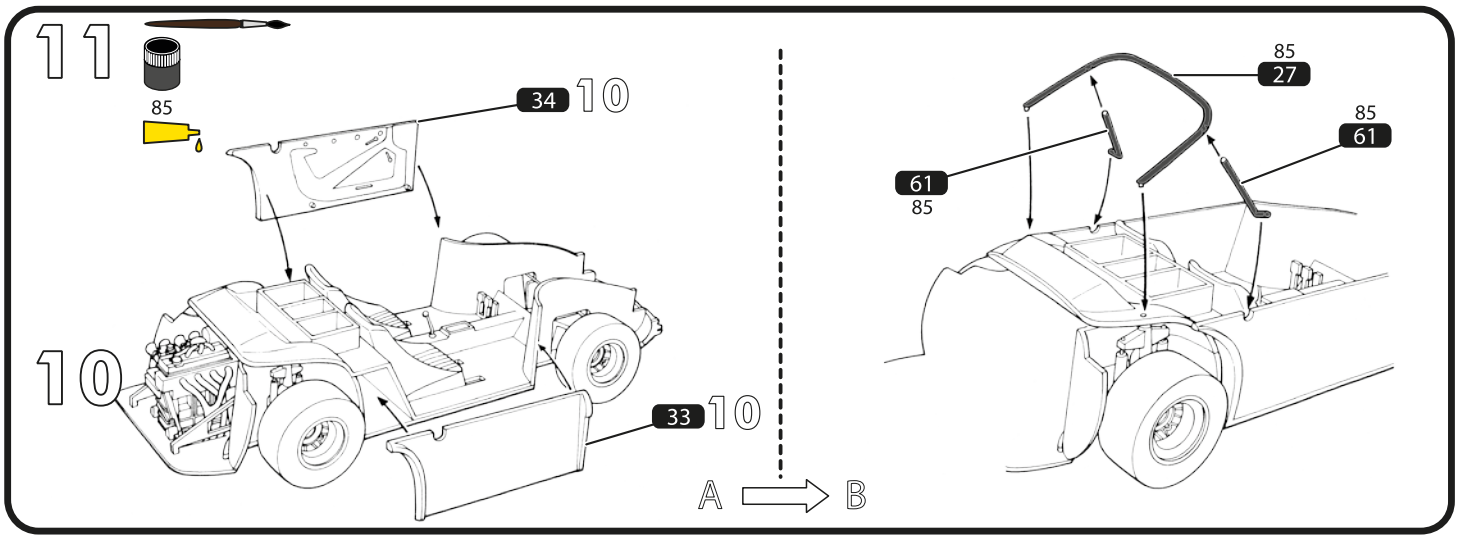

# 15

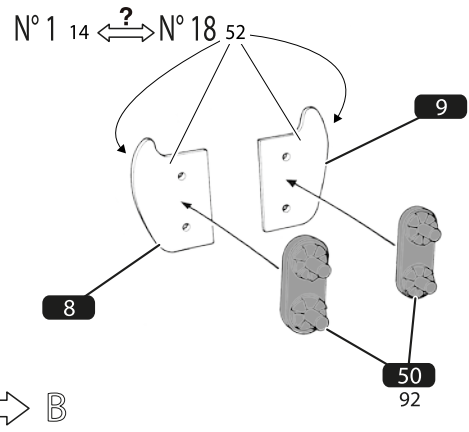
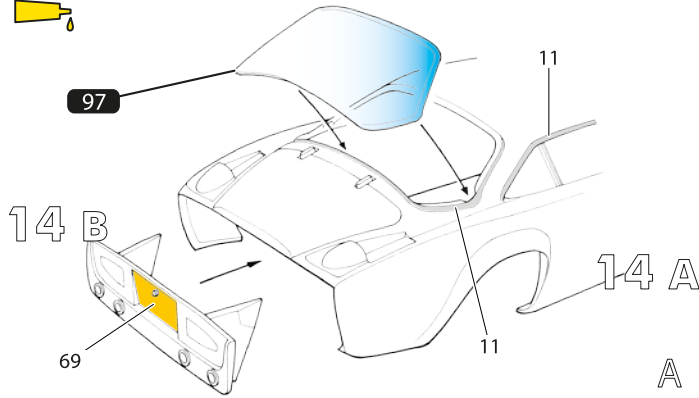
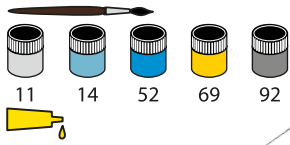

# 16

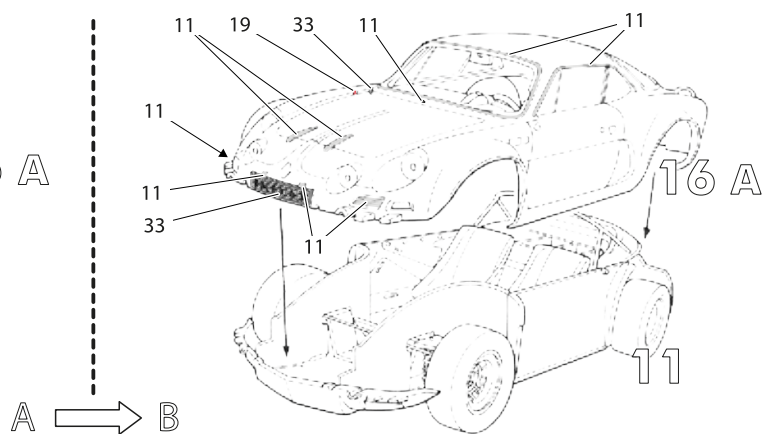
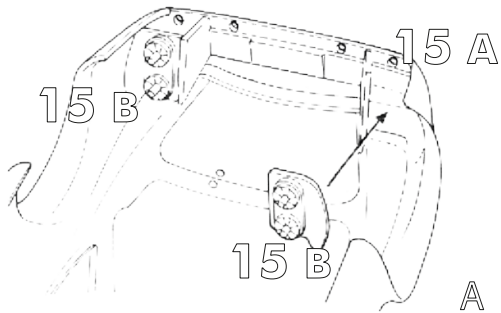
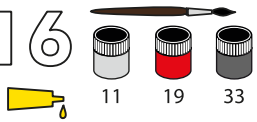

# 17

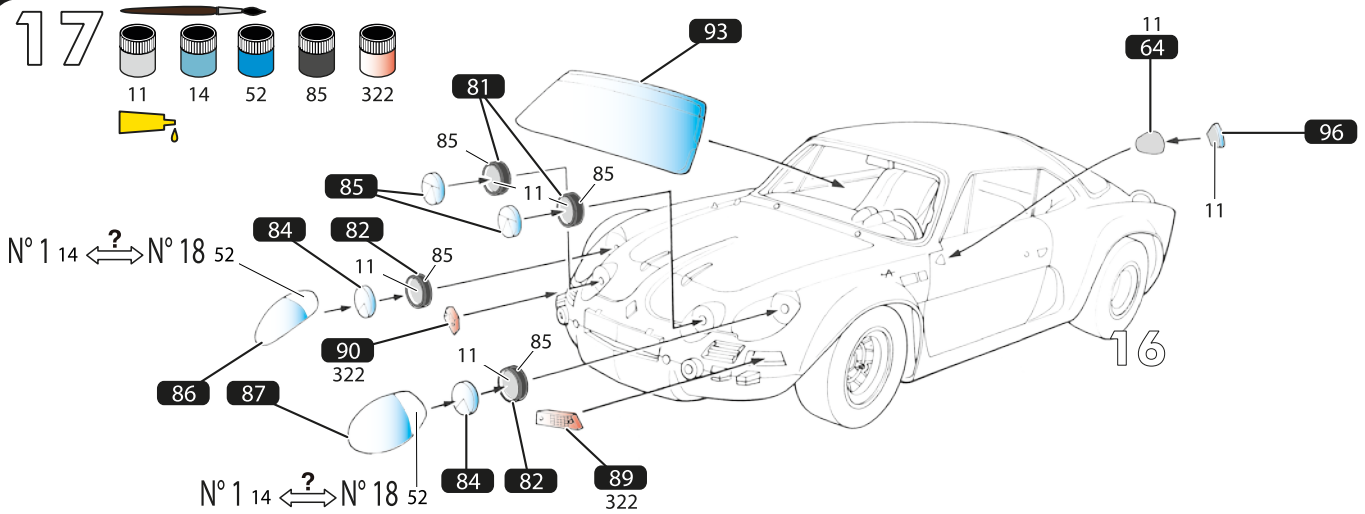
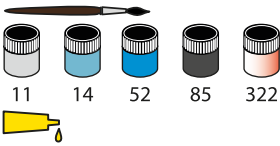

# 18

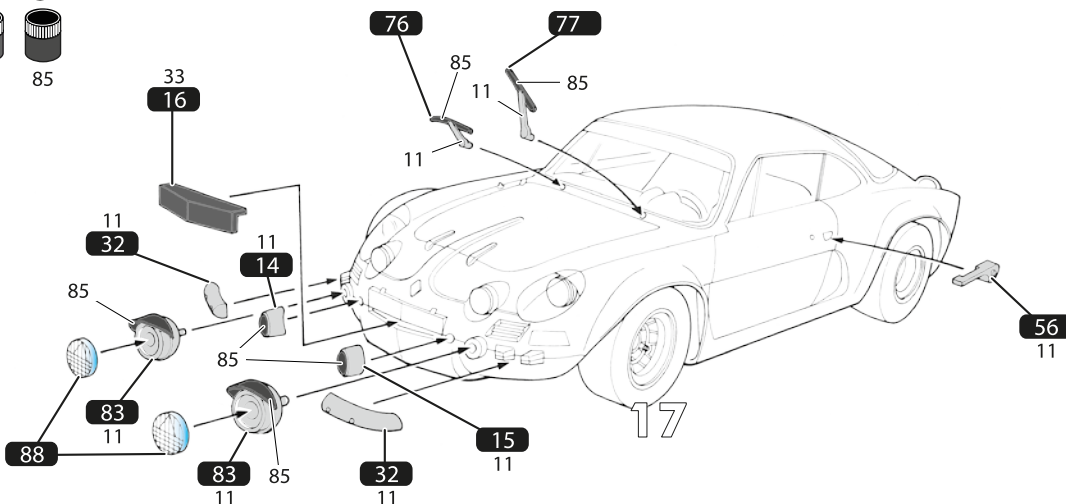
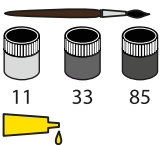

19

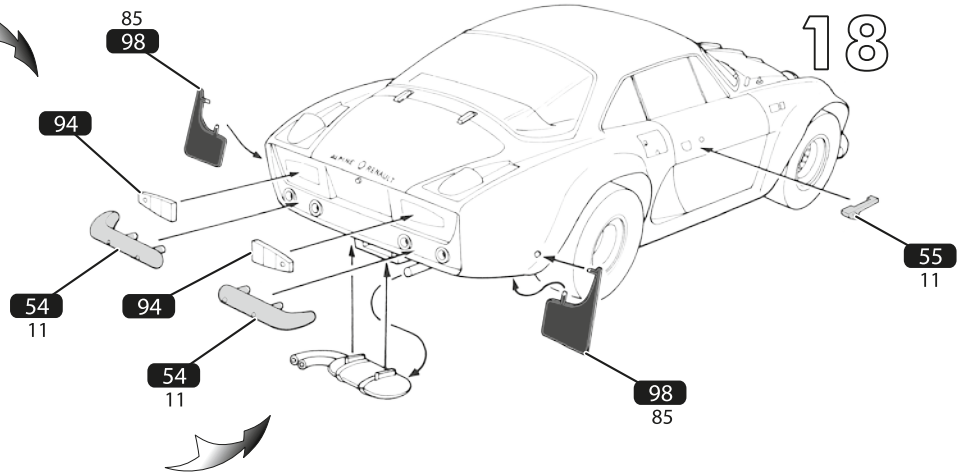
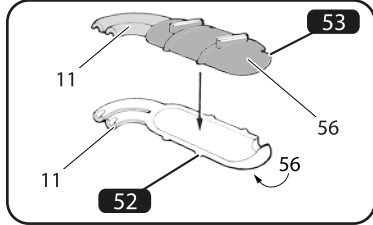
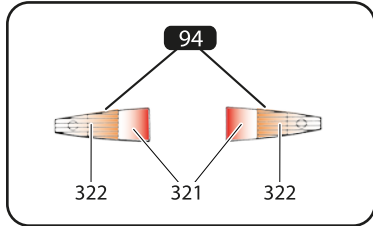
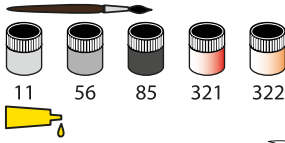

# CARROSSERIE

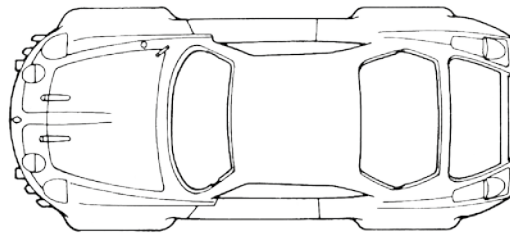

1

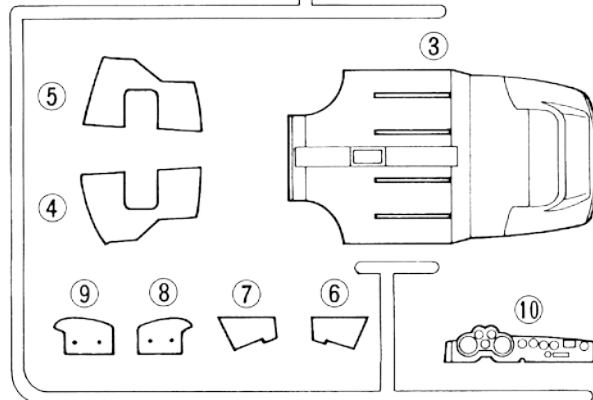
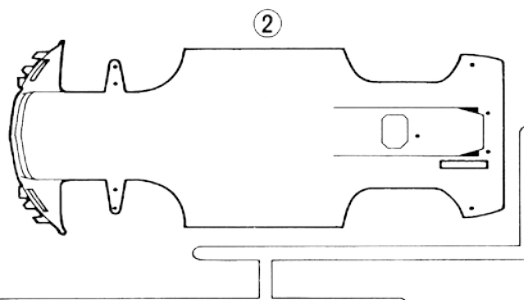

2

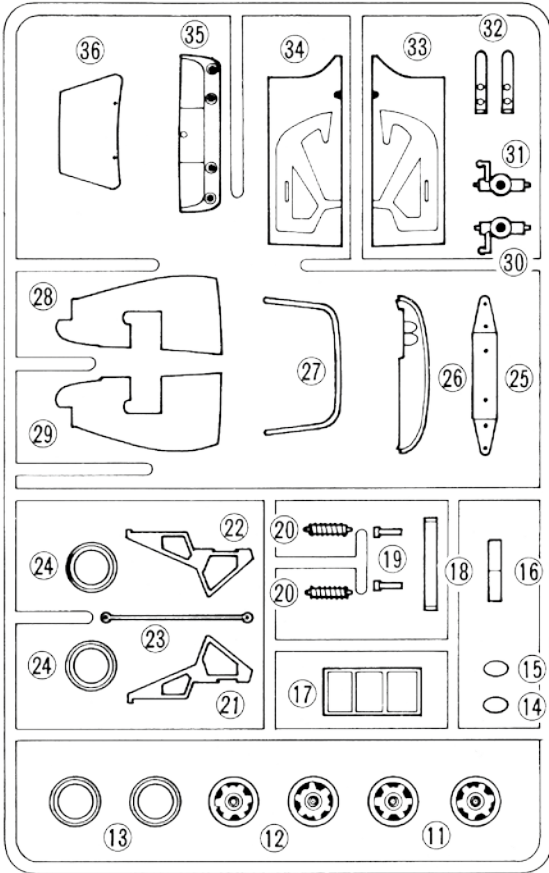

3

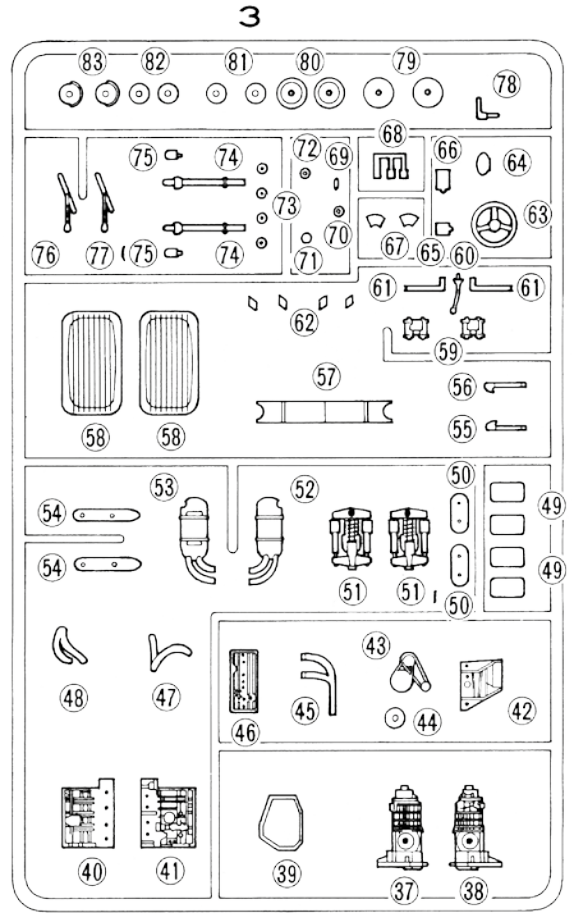

4

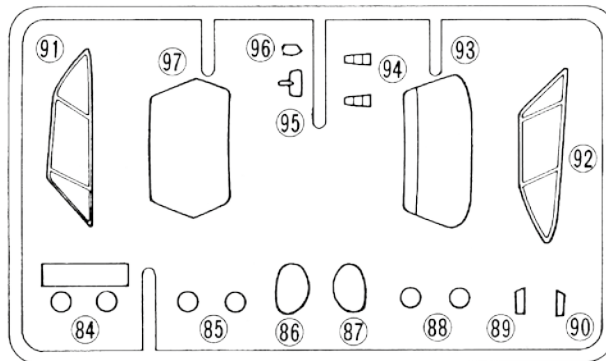

5

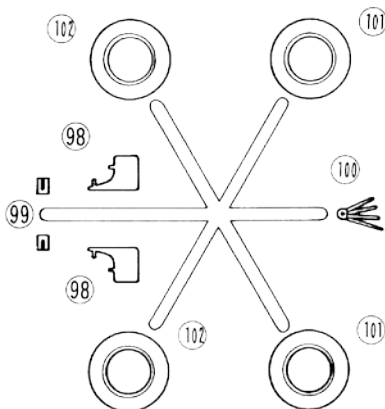

2

Número de fase  
Step number  
Schrittnummer  
Número de fase

37

Número de pièce  
Part number  
Teilnummer  
Número de pieza

56

Référence de couleur  
Colour reference no  
Farbangebe  
Referencia de color

6

Número de decal  
Decal number  
Nummer von Abziehbild  
Número de calcomanía



20

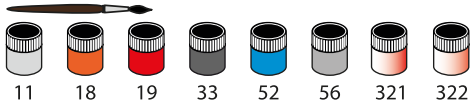

1600



JEAN CLAUDE ANDRUET / «BICHE»  
1ère place Rallye de Monte Carlo 1973

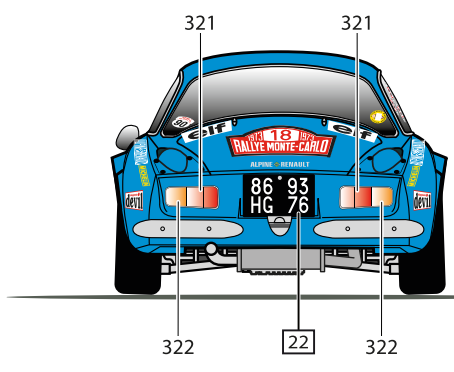
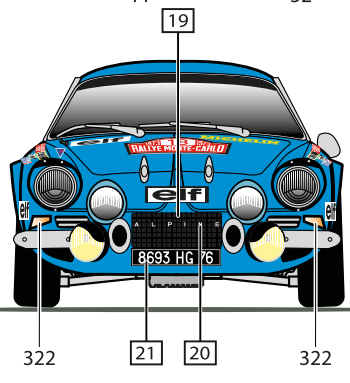
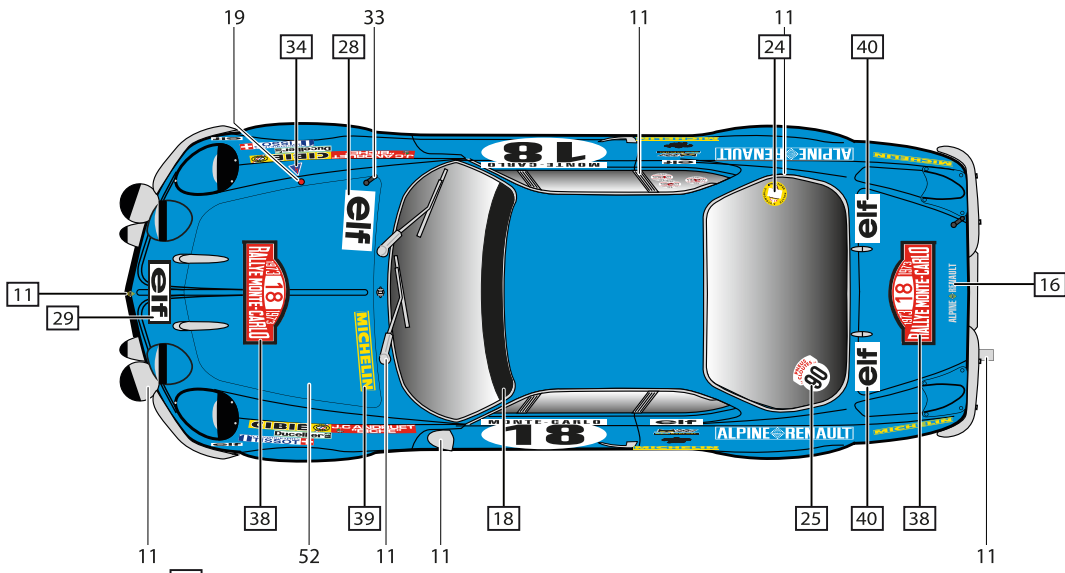
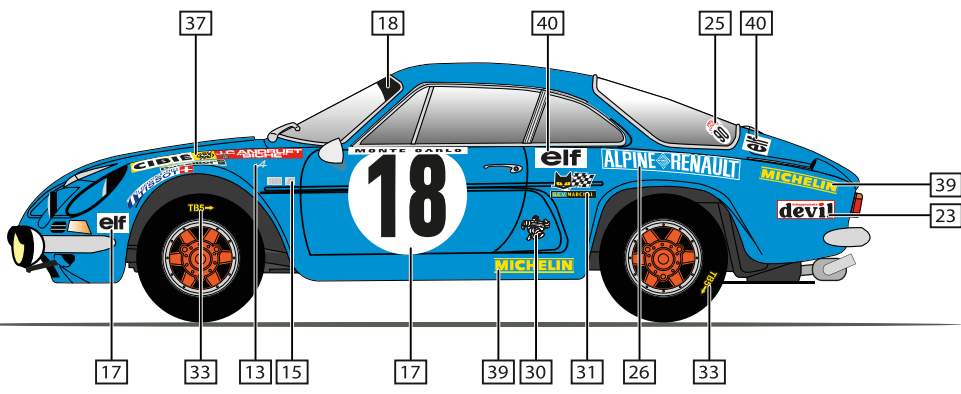
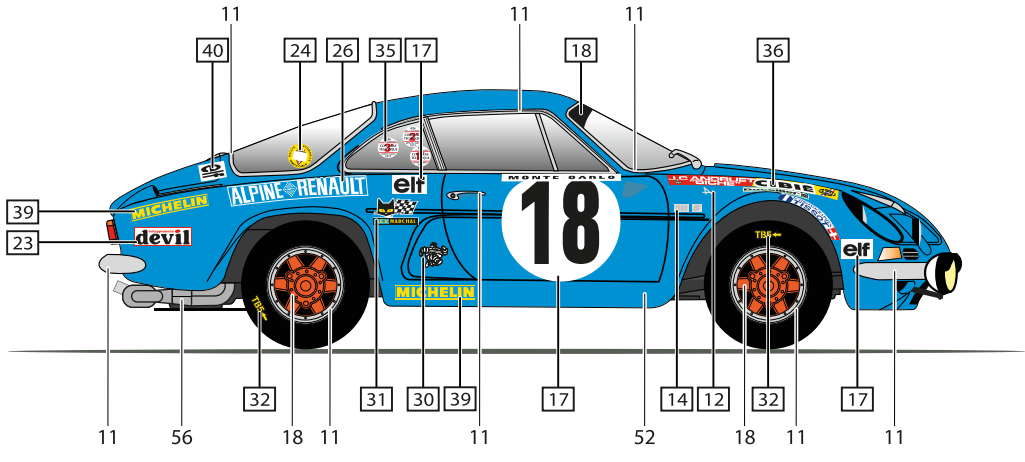

21

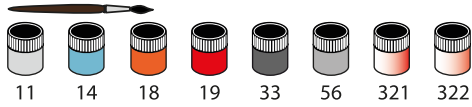

ALPINE RENAULT

1600

5

JEAN PIERRE NICOLAS / MICHEL VIAL  
1ère place Tour De Corse 1973

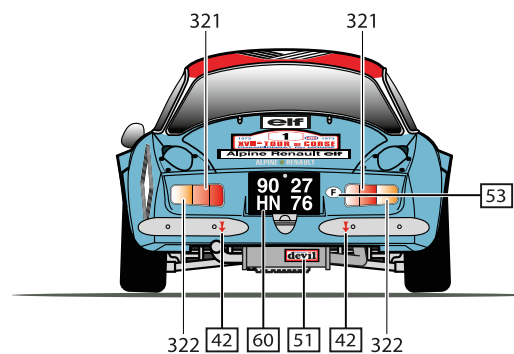
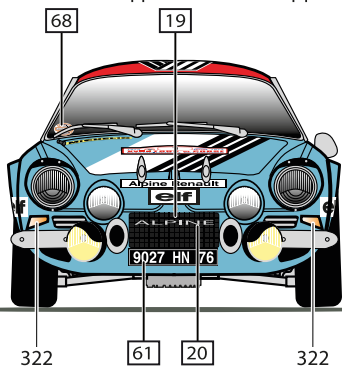
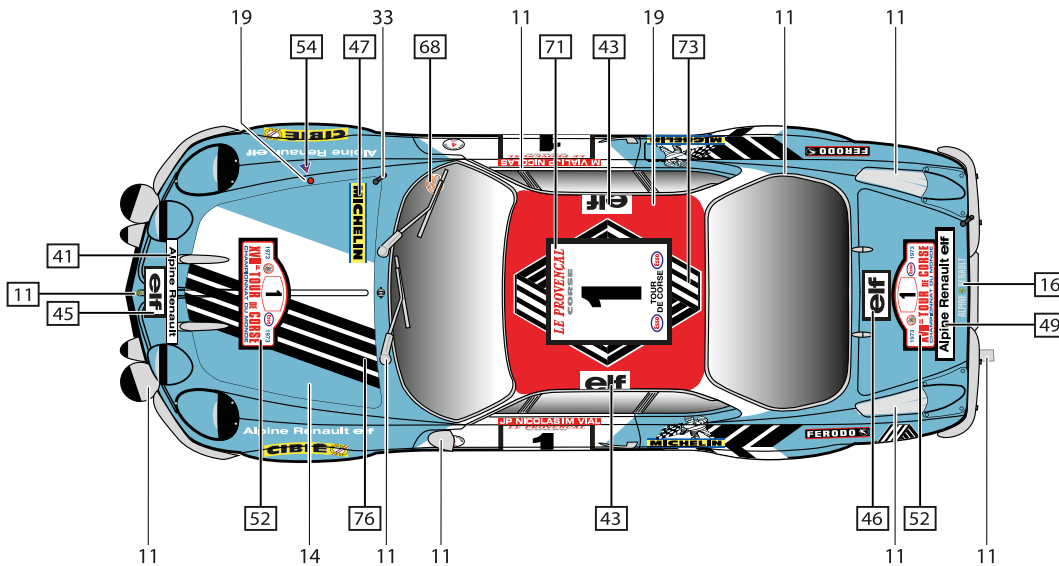
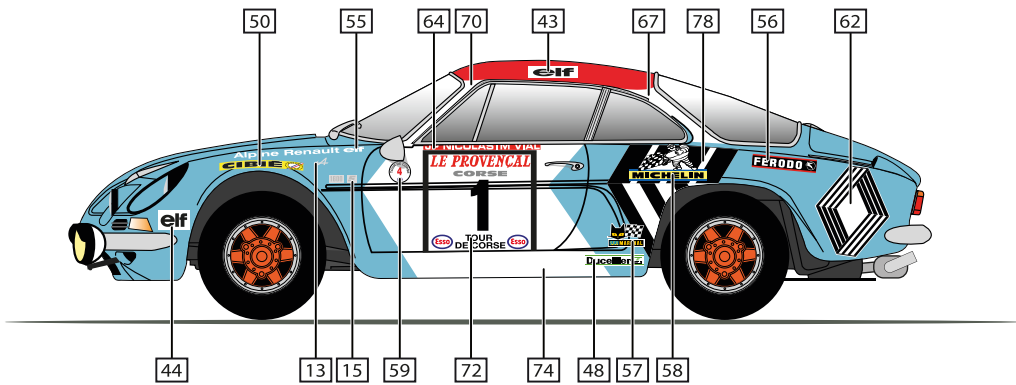
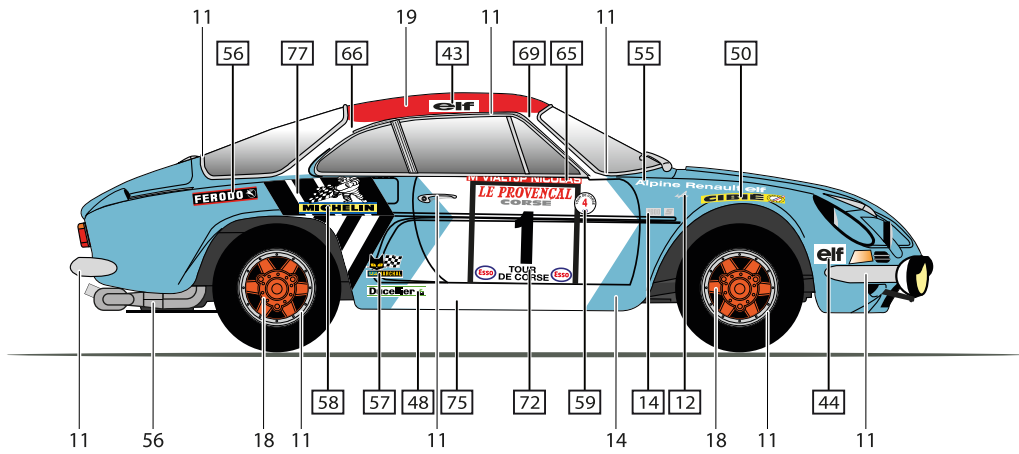

# VISITEZ-NOUS SUR LES RÉSEAUX SOCIAUX

VISIT US ON SOCIAL MEDIA!  
BESUCHEN SIE UNS AUF SOCIAL MEDIA!

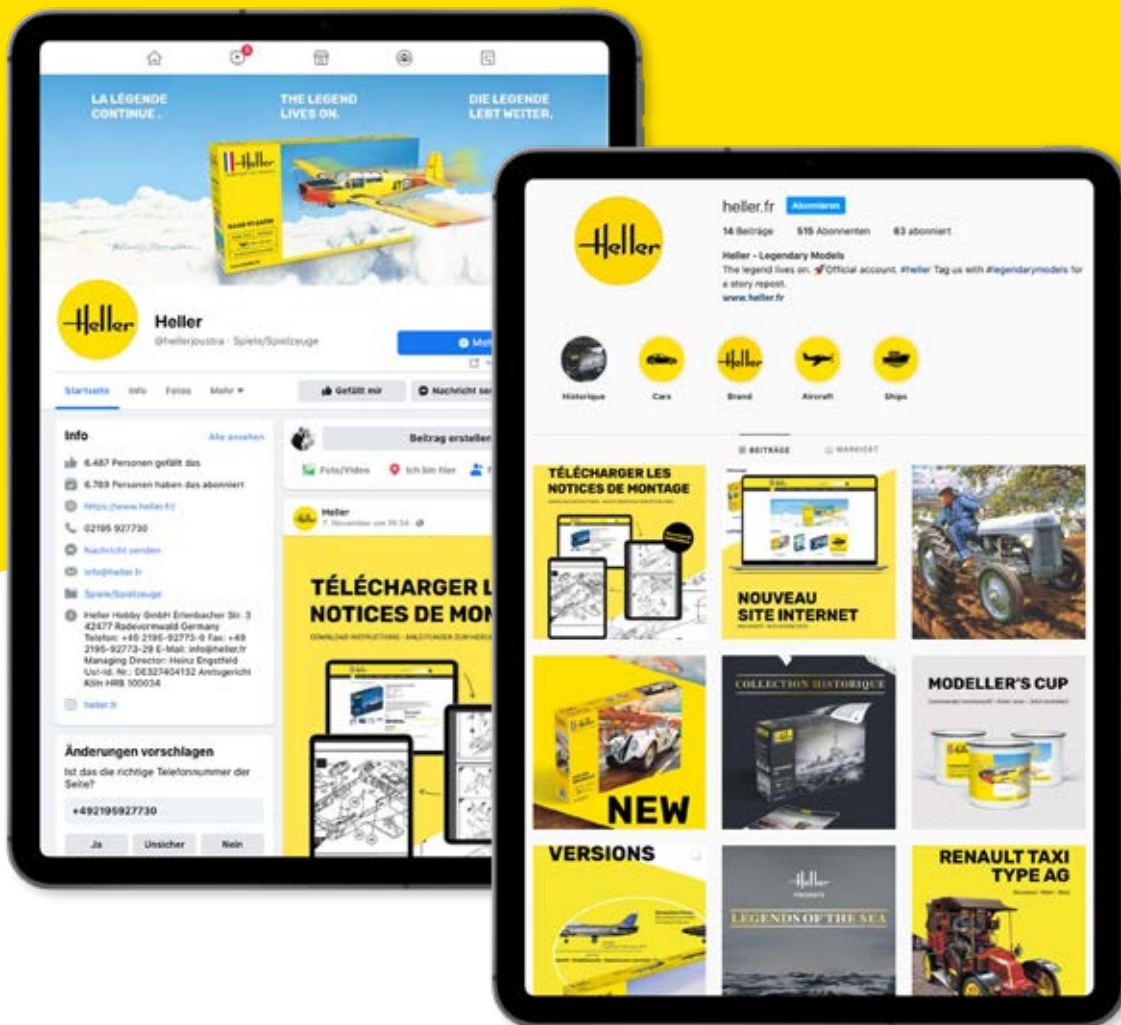

@instagram.com/heller.fr • facebook.com/heller.fr

# VISITEZ-NOUS EN LIGNE !

VISIT US DIGITALLY!  
BESUCHEN SIE UNS DIGITAL!

 [www.heller.fr](http://www.heller.fr)

 [instagram.com/heller.fr](https://www.instagram.com/heller.fr)

 [facebook.com/heller.fr](https://www.facebook.com/heller.fr)

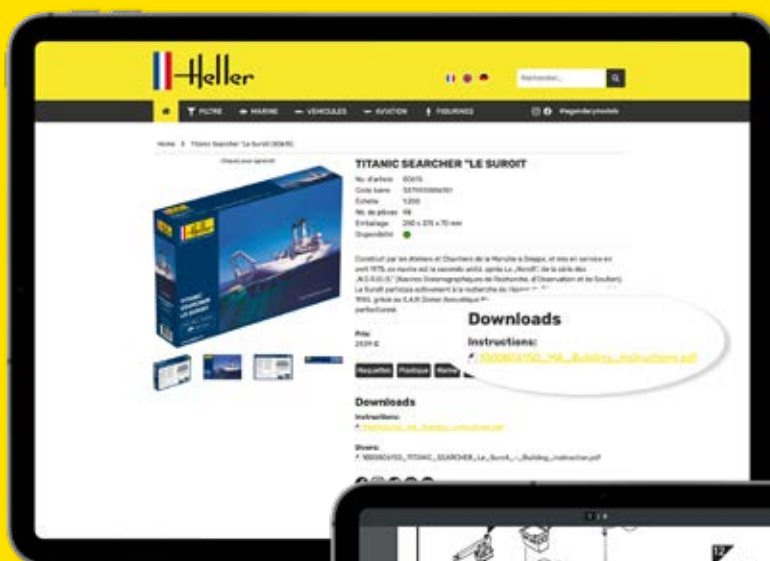

Choisissez l'article que vous désirez et téléchargez les instructions.  
Choose your desired article and download the instructions.  
Wählen Sie den gewünschten Artikel und laden Sie die Anleitung herunter.



**Download all  
instructions!**

Grossissement des instructions pour  
une vue détaillée.

Enlarge the instructions for a more  
detailed view.

Vergrößern Sie die Anleitung für eine  
detailliertere Ansicht.

V-070421

**Service consommateurs**  
Pour toute demande de SAV, connectez-vous  
sur notre site [www.heller.fr](http://www.heller.fr).

**Customer Service**  
For after-sales service requests,  
please contact us through our website  
[www.heller.fr](http://www.heller.fr).

**Endverbraucherservice**  
Bitte besuchen Sie uns auf [www.heller.fr](http://www.heller.fr)  
für alle Ersatzteilanfragen.

**Heller Hobby GmbH**

Erlenbacher Str. 3 • 42477 Radevormwald • GERMANY

☎ +49 (0) 2195-92773-0 ✉ [info@heller.fr](mailto:info@heller.fr)